

-04P1

Montageanweisung / Installation instructions / Instruction de montage / Istruzioni di montaggio
montagehandleiding / Instrukcja montażu / Montaj talimatlar / Osszeszerelési útmutató / Nàvod k montáži /
Nàvod na montaž / Instrucțiune de montaj / Инструкция по монтажу / Montaj talimatina / Monteringsanvisningar
Upute za montažu / Instrucciones de Montaje / Navodila za montažo

INFINITY



60 Min.

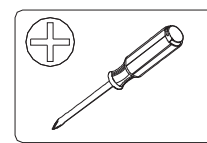
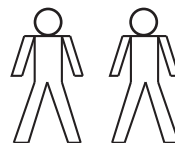

D Bitte lesen Sie diese Montageanleitung gut durch, da wir für Fehler, die durch falsche Montage entstehen, keine Haftung übernehmen!

GB Please read these installation instructions through carefully as we cannot accept any liability for faults occurring as a result of incorrect installation!

CZ Přečtěte si prosím pozorně tento návod k montáži, aby jste předešli chybám vzniklých špatnou montáží, za které neručíme!

F Veuillez lire attentivement cette notice de montage, car nous déclinons toute responsabilité en cas d'erreurs découlant d'un montage erroné !

I Prego leggere attentamente le istruzioni per il montaggio, poiché decliniamo qualsiasi responsabilità per difetti derivanti da un montaggio errato

S Läs monteringsanvisningarna noggrant. Vi avsåger oss allt ansvar för defekter som uppstår p.g.a. felaktig montering.

HR Pažljivo pročitajte upute za montažu, jer otklanjamo svaku odgovornost za pogreške nastale uslijed pogrešne montaže.

SLO Prosimo, da pozorno preberete navodila za montažo, saj zavračamo vsakršno odgovornost za napake, ki bi nastale zaradi napačne montaže.

NL Leest u alstublieft deze montagehandleiding goed door, voor fouten door verkeerde montage zijn wij niet verantwoordelijk.

PL Proszę uważnie zapoznać się z instrukcją montażu, ponieważ nie ponosimy odpowiedzialności za niewłaściwy montaż.

HU Kérjük, olvassa el figyelmesen ezt az összeszerelési útmutatót, mert a helytelen összeszerelésből a dódó hibákért nem vállalunk felelősséget!

SK Prosíme, dobre prečítajte si tento návod na montáž, pretože nepreberáme žiadne ručenie za chyby, ktoré vzniknú na základe chybnej montáže!

RO Vă rugăm să citiți cu atenție aceste instrucțiuni de montaj deoarece nu preluăm garanția pentru defecte ce apar datorită unui montaj incorect!

RUS Пожалуйста, внимательно ознакомьтесь с данной инструкцией по монтажу, поскольку мы не несем ответственности за ошибки, причиной которых является неправильный монтаж.

TU İlkonce kullanma klavuzunu iyi okuyun, yanlış montaj yaparsanız bunun sorumlusu biz degiliz.

E Se ruego leer con atención las instrucciones de montaje debido a que declinamos cualquier responsabilidad por defectos derivados de un montaje erróneo

LC S.p.A
Via del Piano s.n
61030 Isola del Piano (PU)
Italia

SERVICEKARTE-SPAREPARTS LIST-CARTE SERVICE-SCHEDA DI SERVIZIO
SERVICEKAART-SERVISNI KARTA-HIZMET KARTI- обслуживание карт

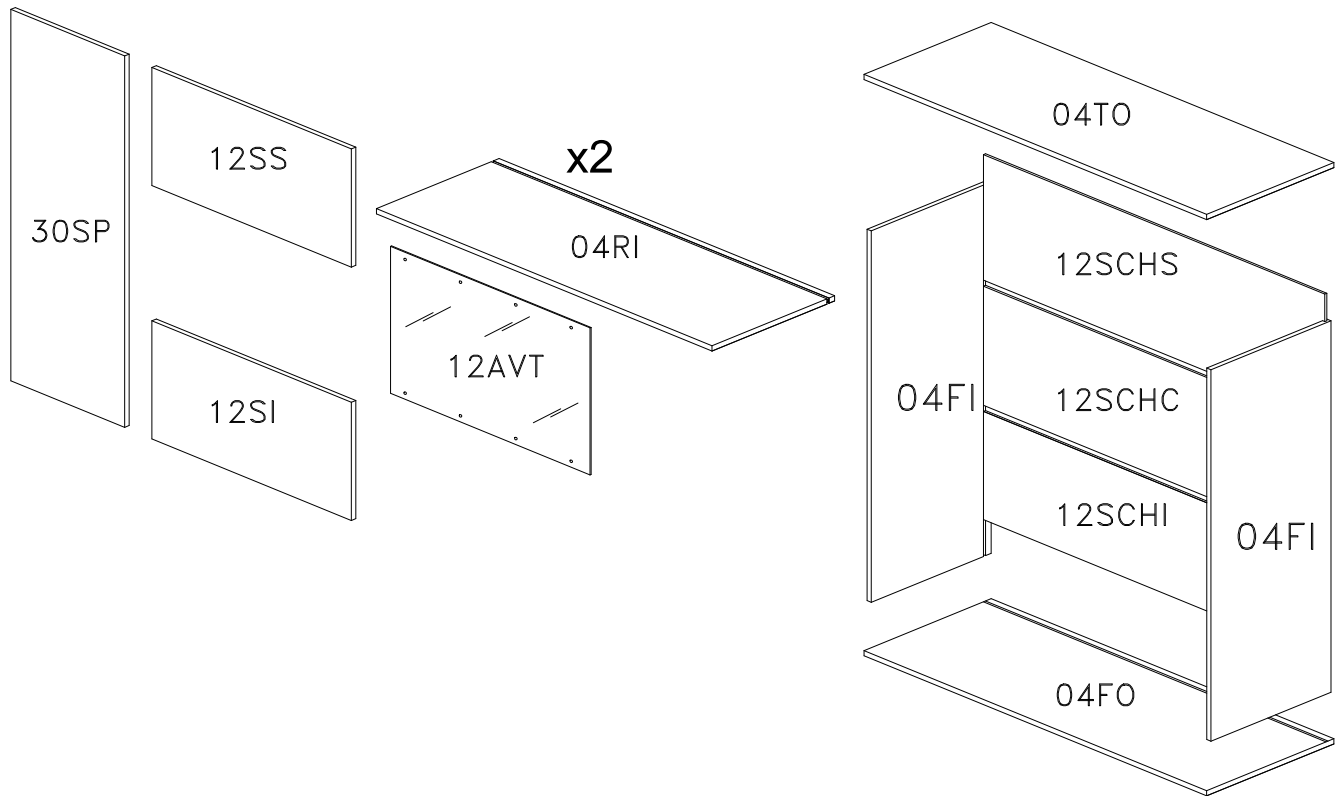

F		L3520		3,5x20 mm.	x4	P14	709042-30CM		x2	TA		x2		
B		8x30 mm.	x8	L418		4x18 mm.	x8	S6		32 mm.	x2	ST		x1
C		∅16 mm.	x8	P14		x8	T1		4x10mm.	x2	AT			
D		x8	P20		∅20 mm.	x8	T27		4x27,5mm.	x2				
P		x4	R2		x8	N1	709042-30CC		x4					
						COS		x4						
						L15		4x15 mm.	x8					

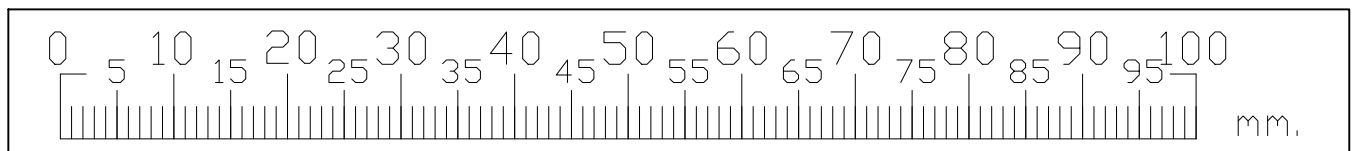

**SERVICEKARTE-SPAREPARTS LIST-CARTE SERVICE-SCHEDA DI SERVIZIO
SERVICEKAART-SERVISNI KARTA-HIZMET KARTI- обслуживание карт**

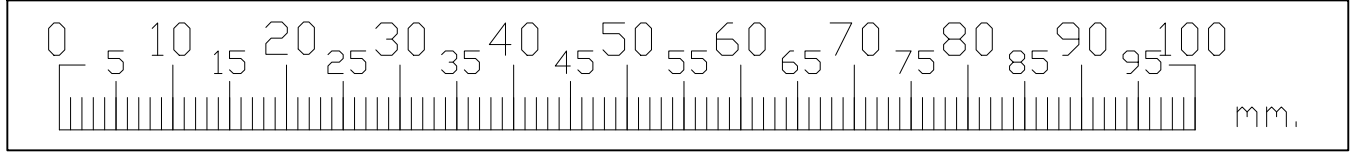
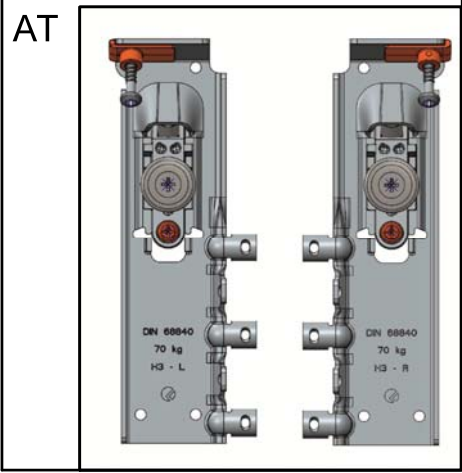
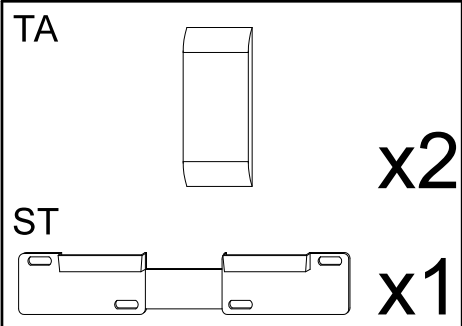
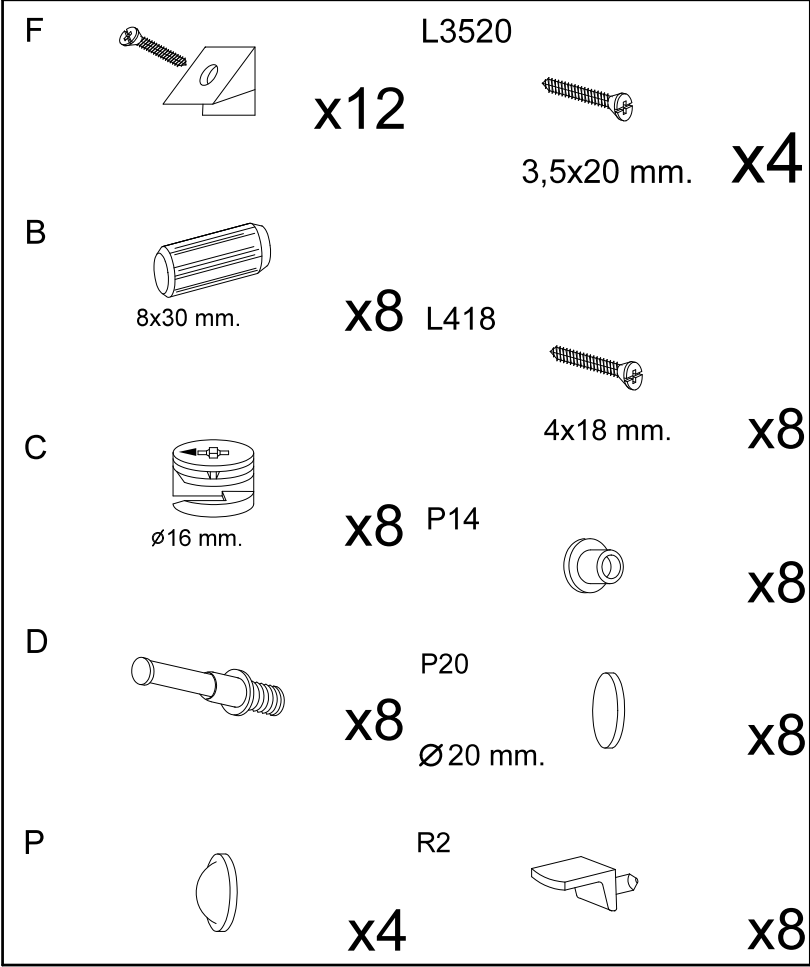
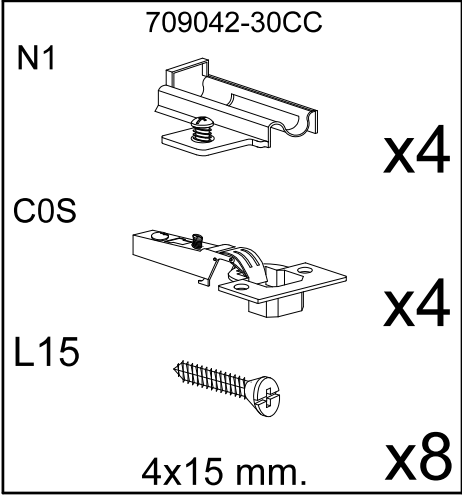
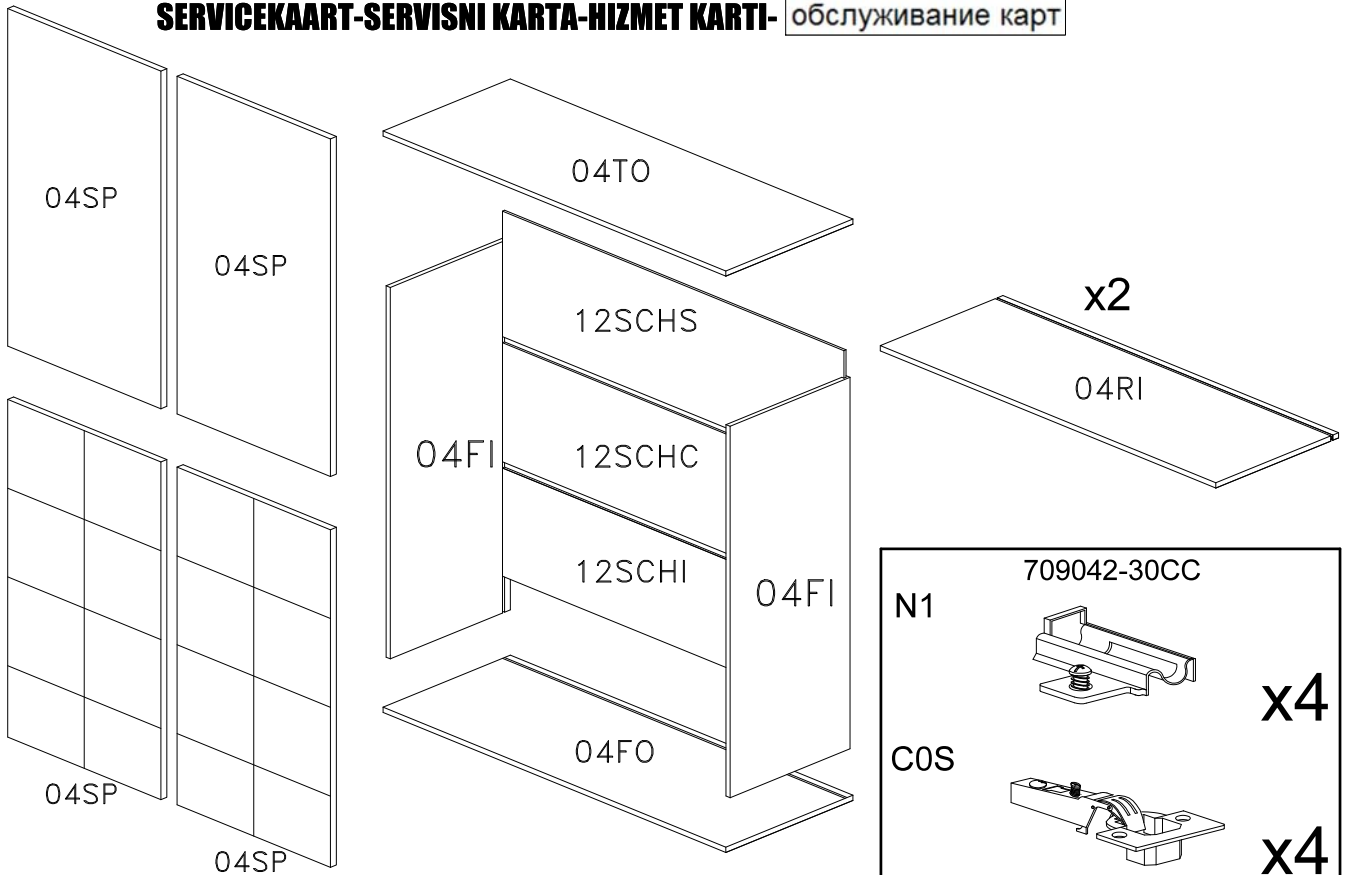

1

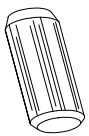
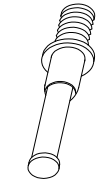
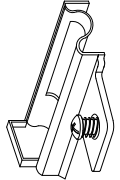
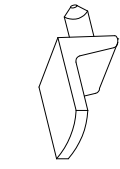
- B  8x30 mm. X8
- D  X8
- N1  X4
- R2  X8

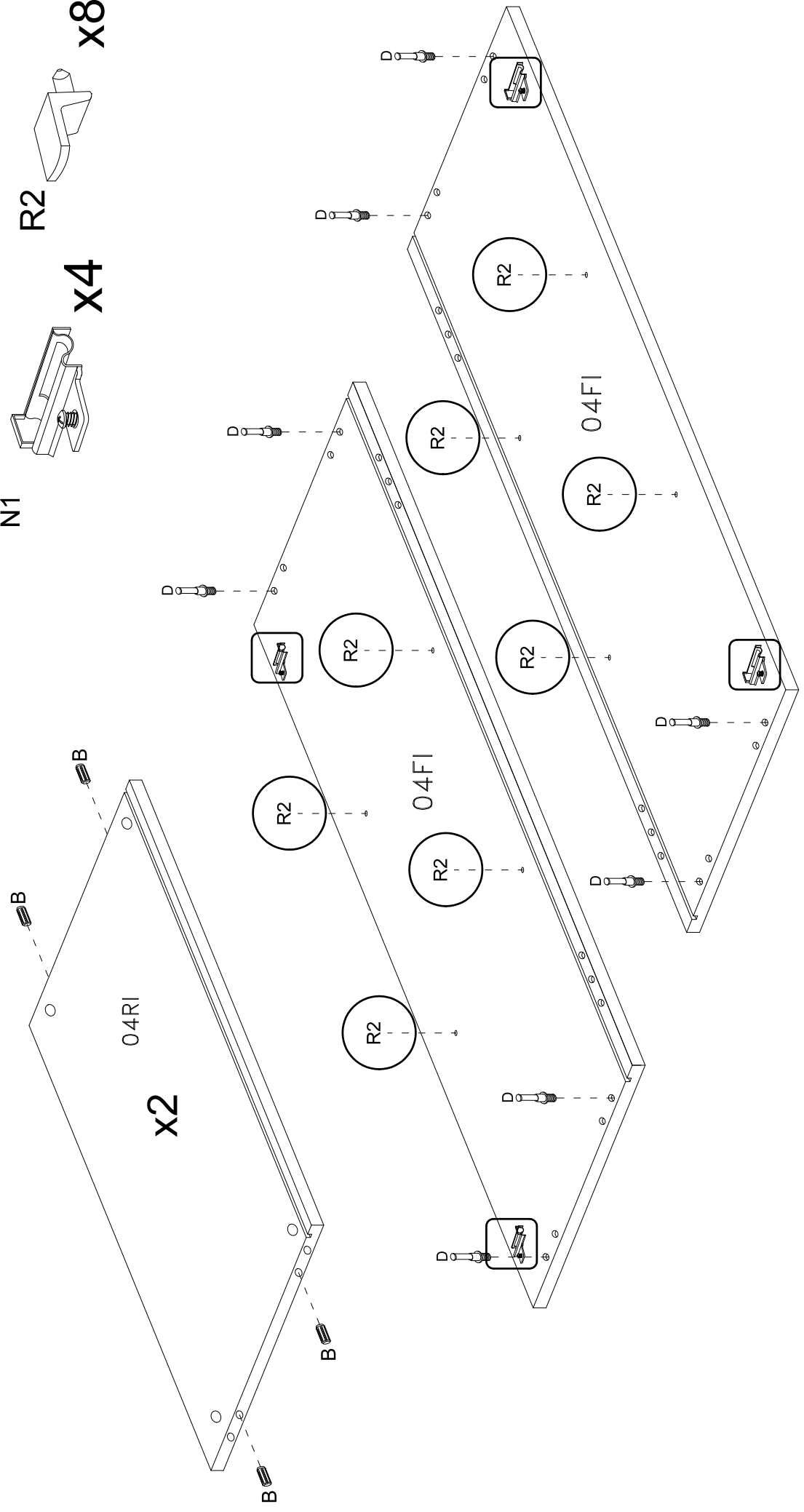

2

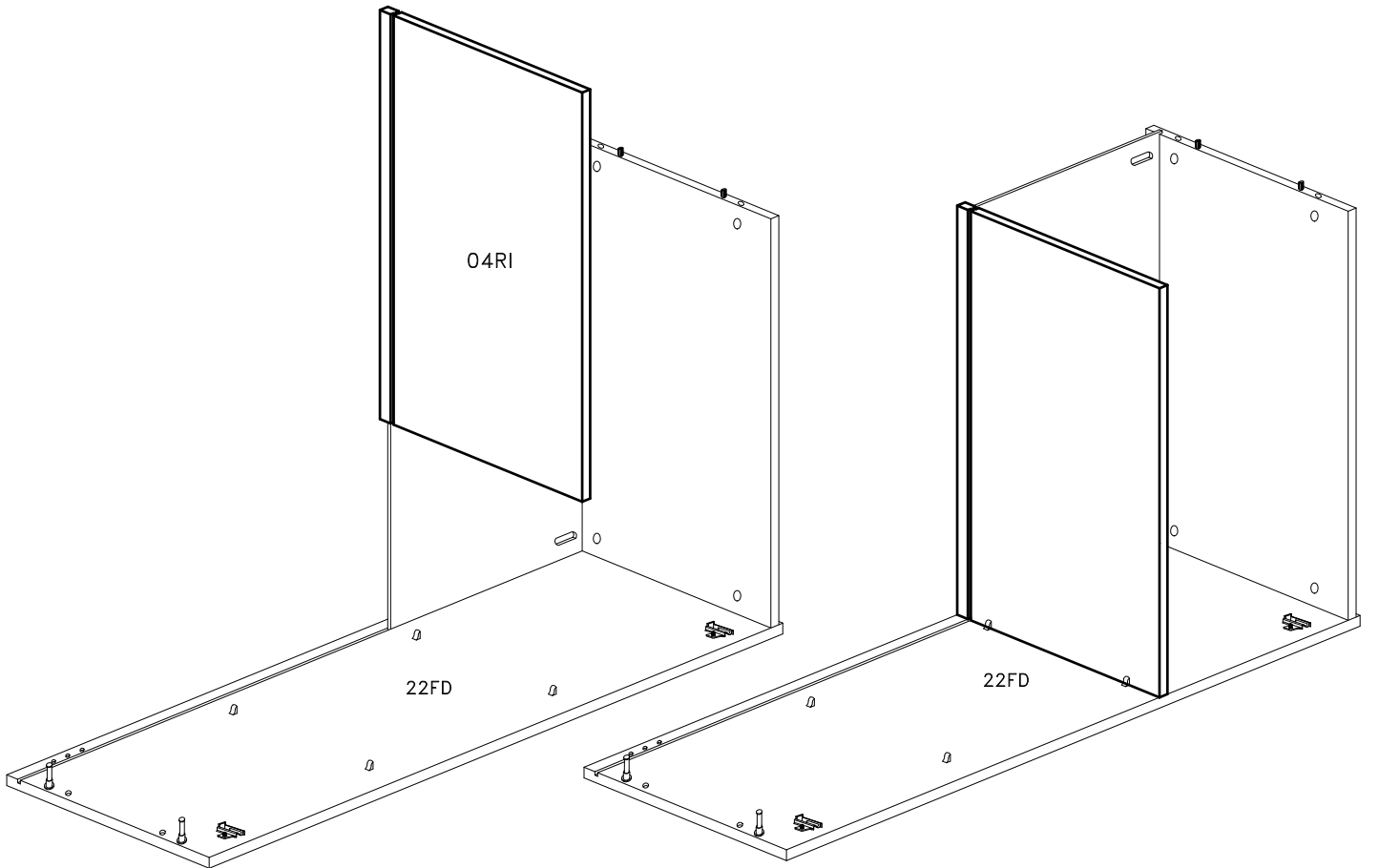
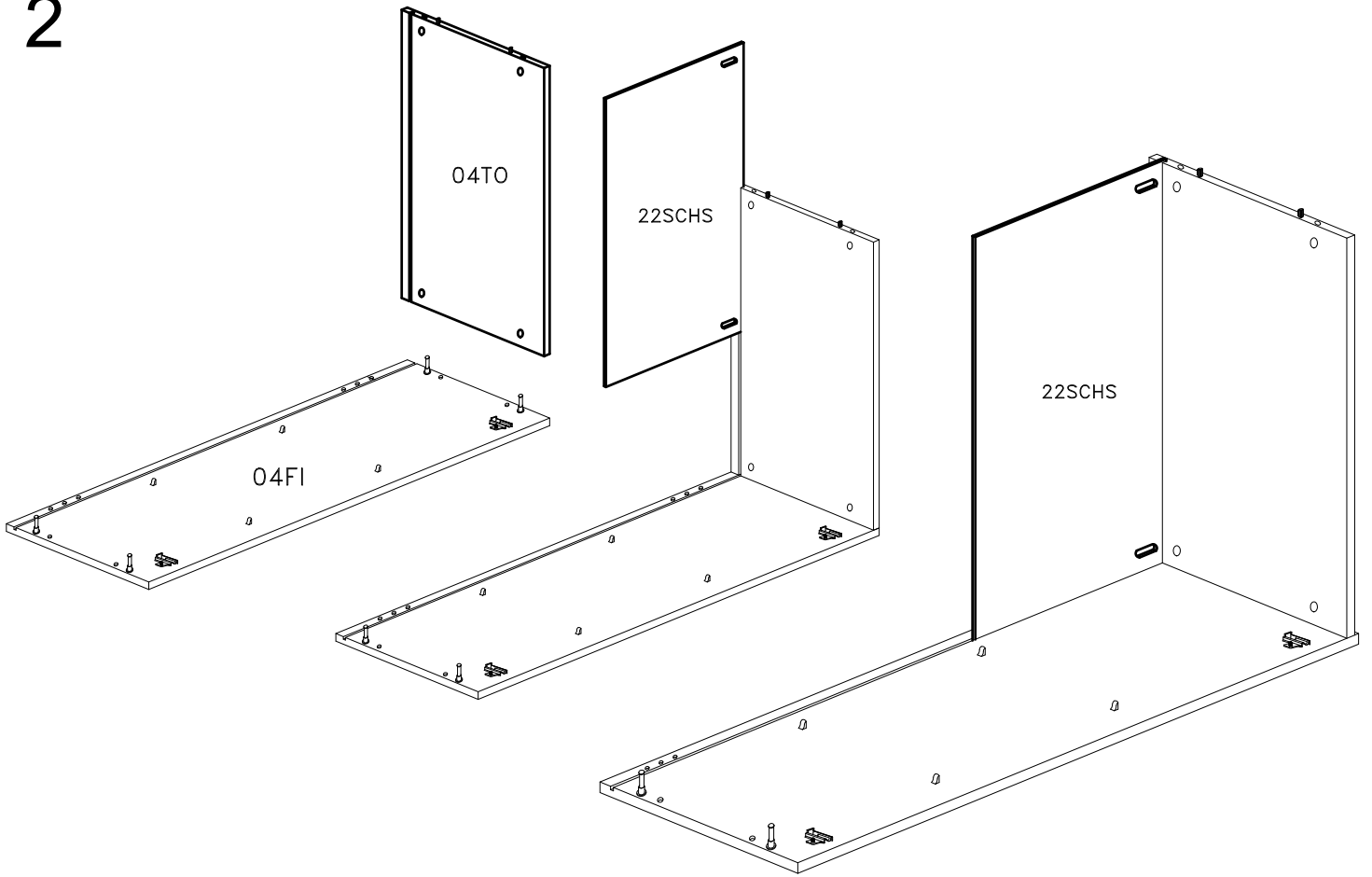

3

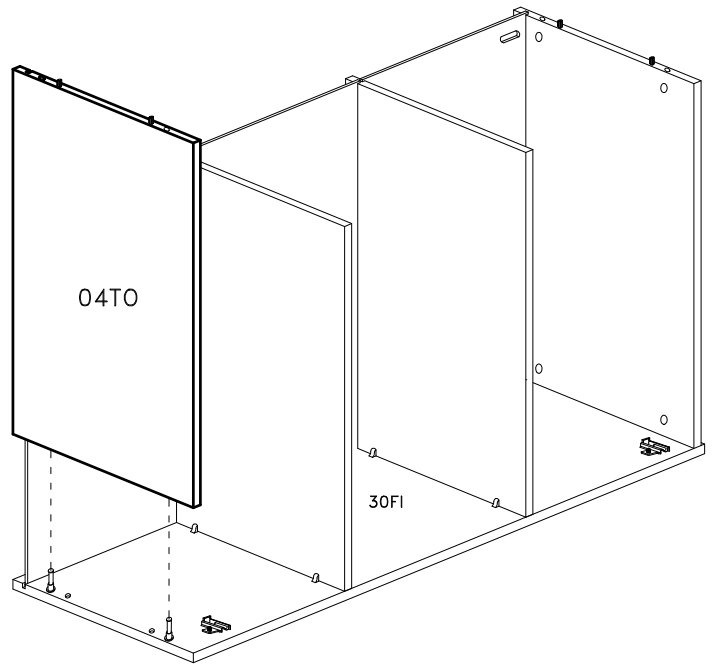
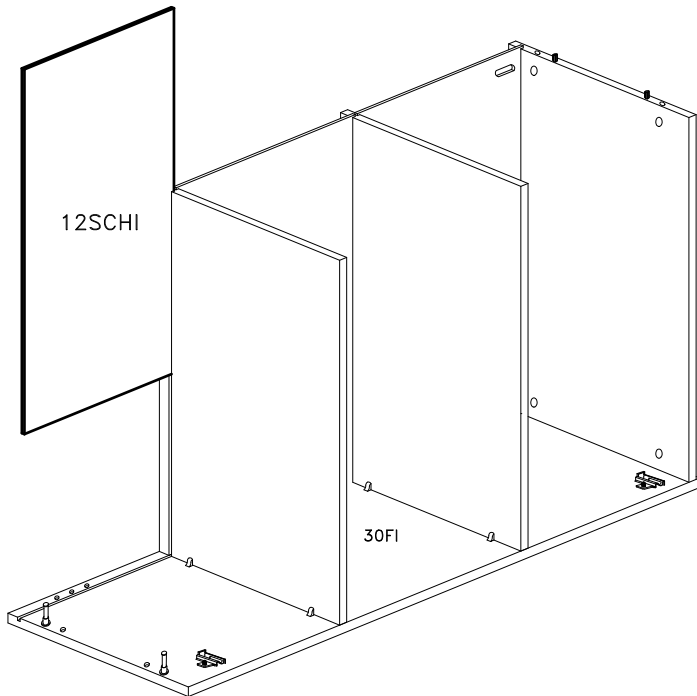
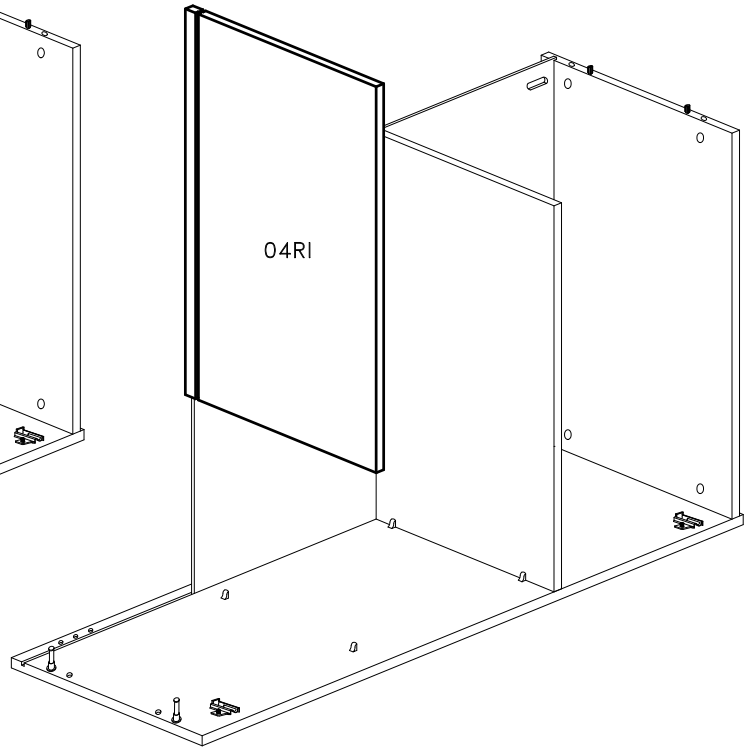
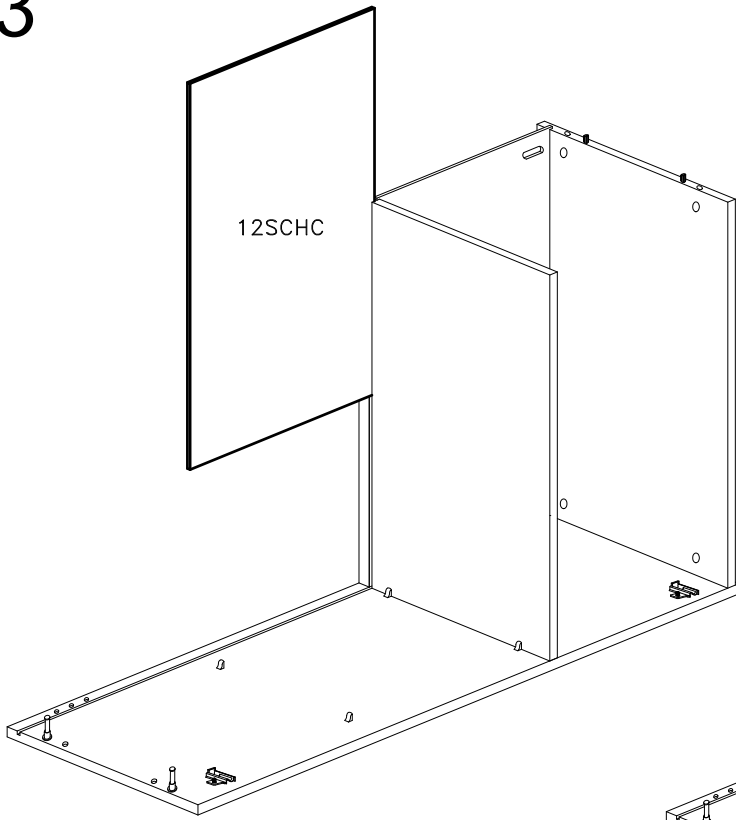

4

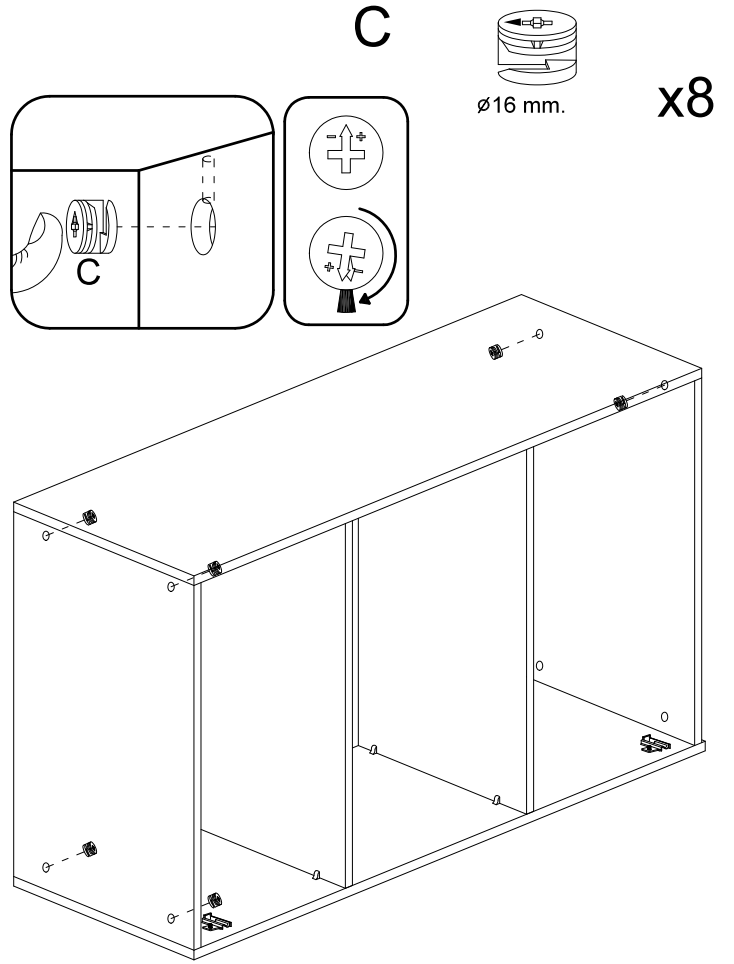
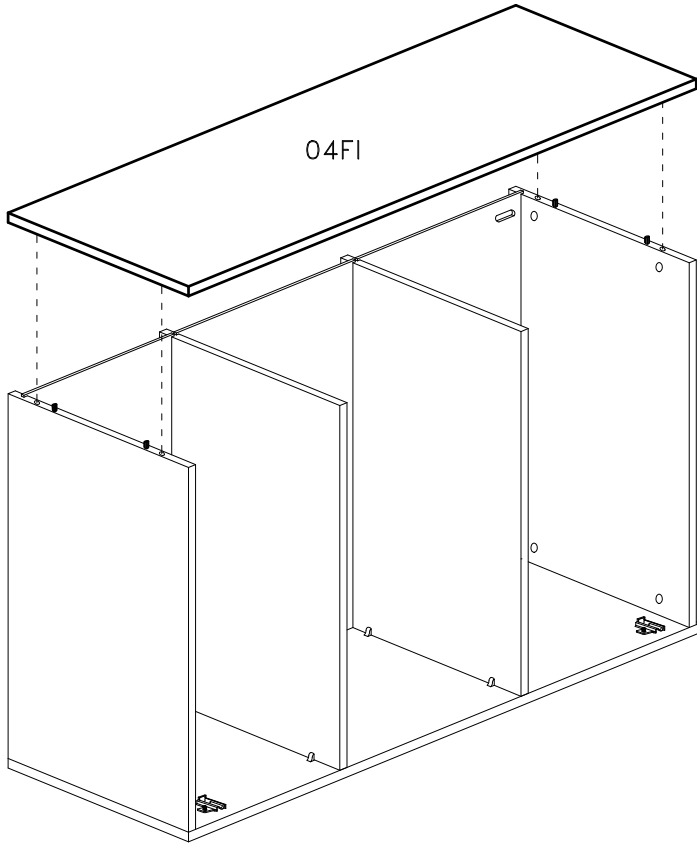

5

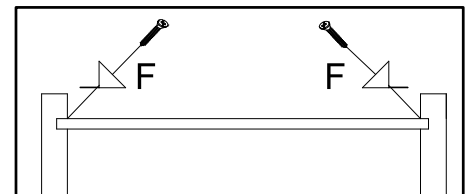
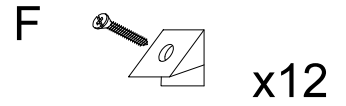
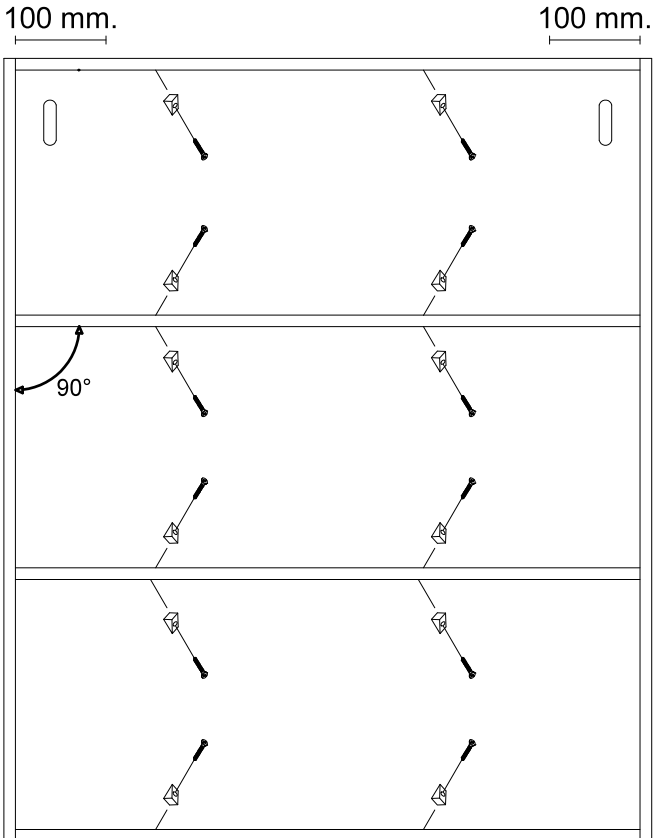

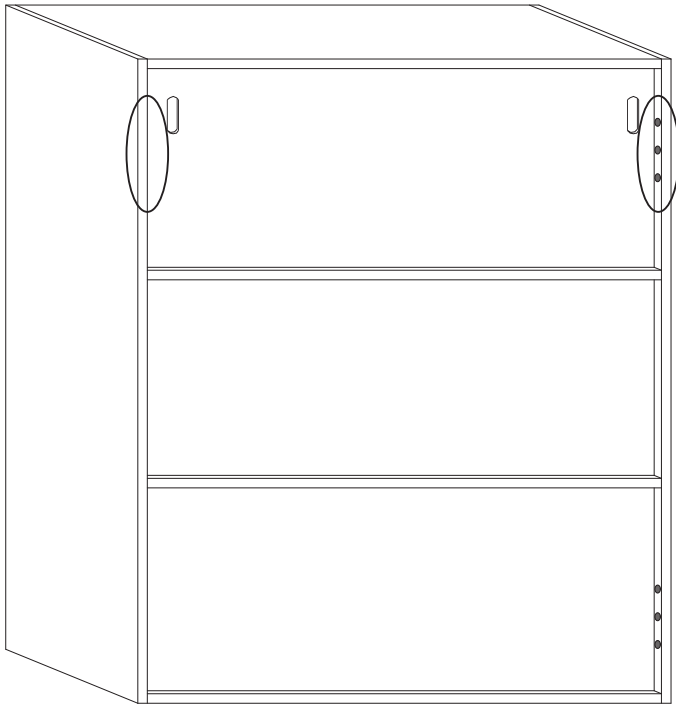

AT

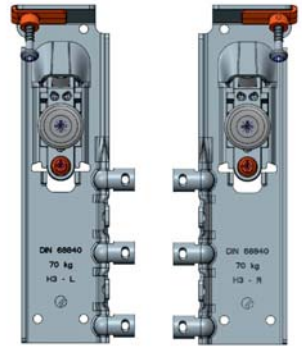

L3520



3,5x20 mm. x4

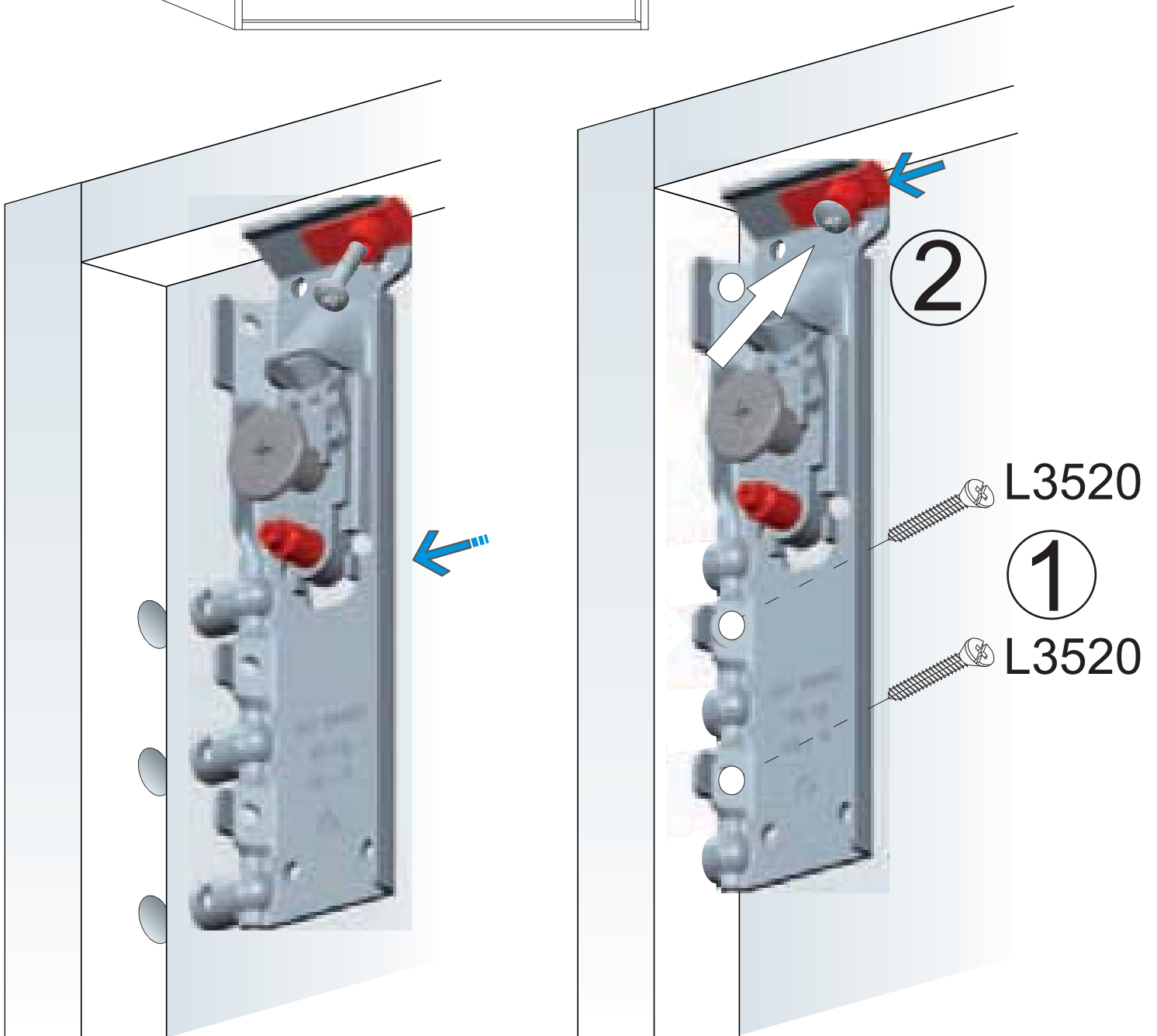

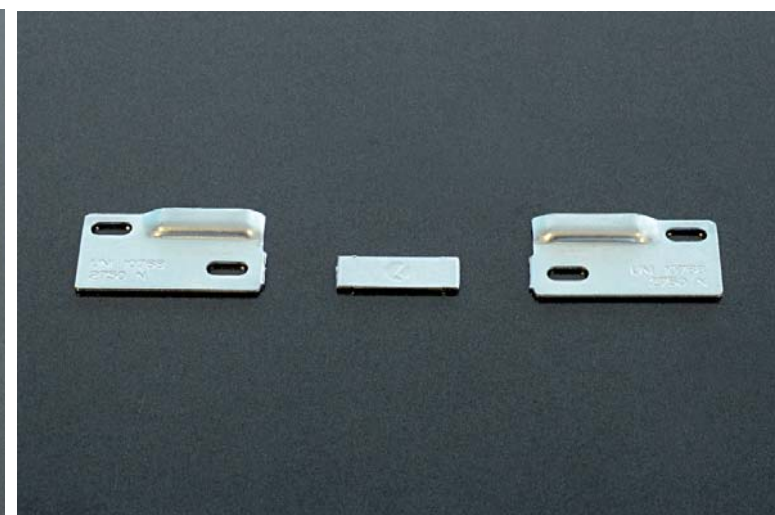
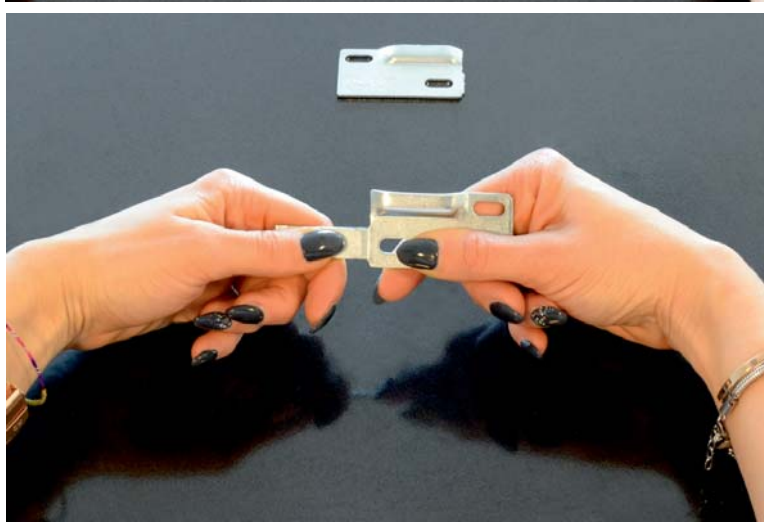
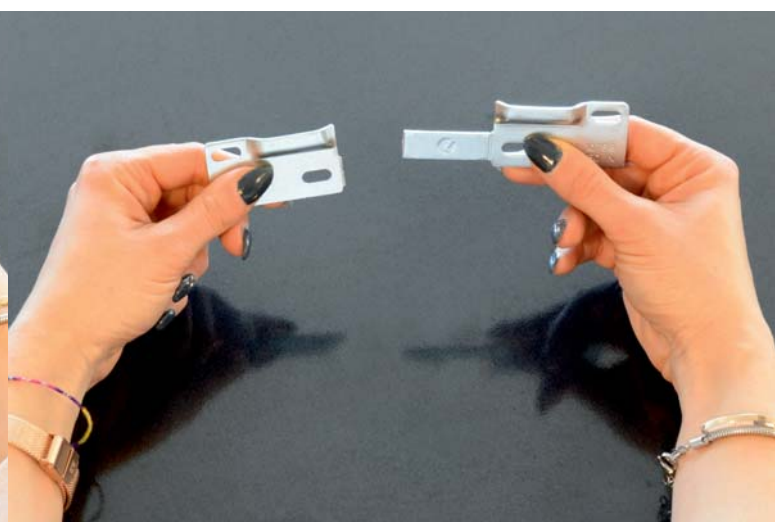
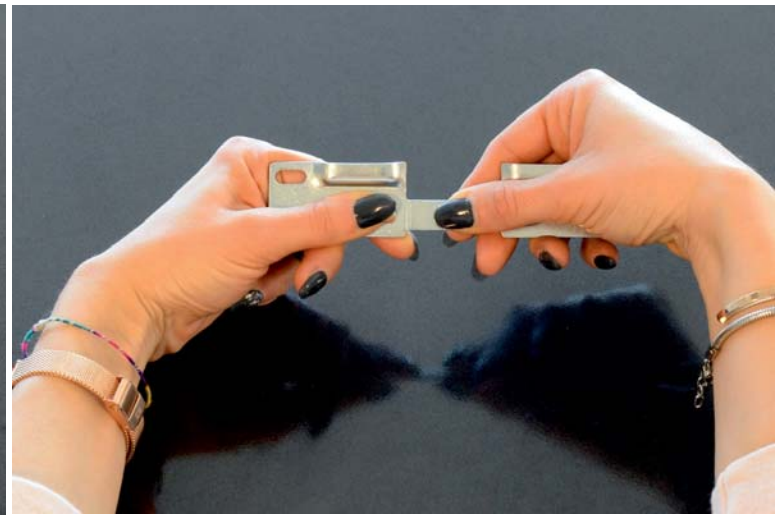
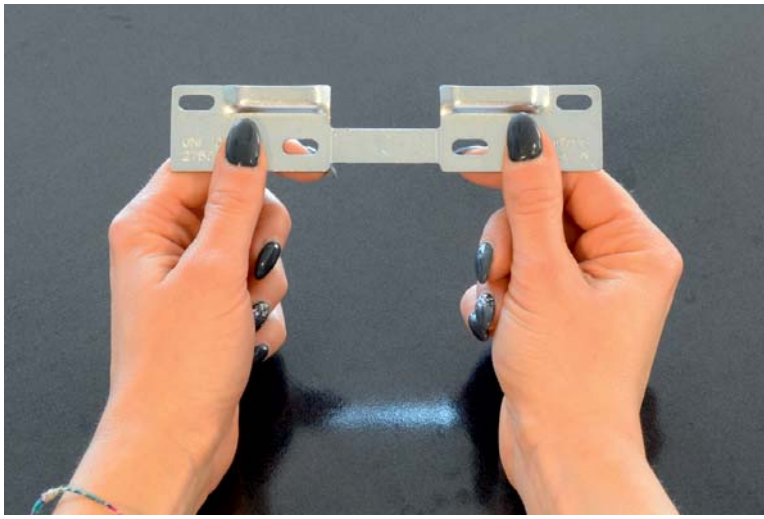

6

ST

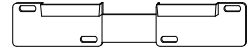

x1

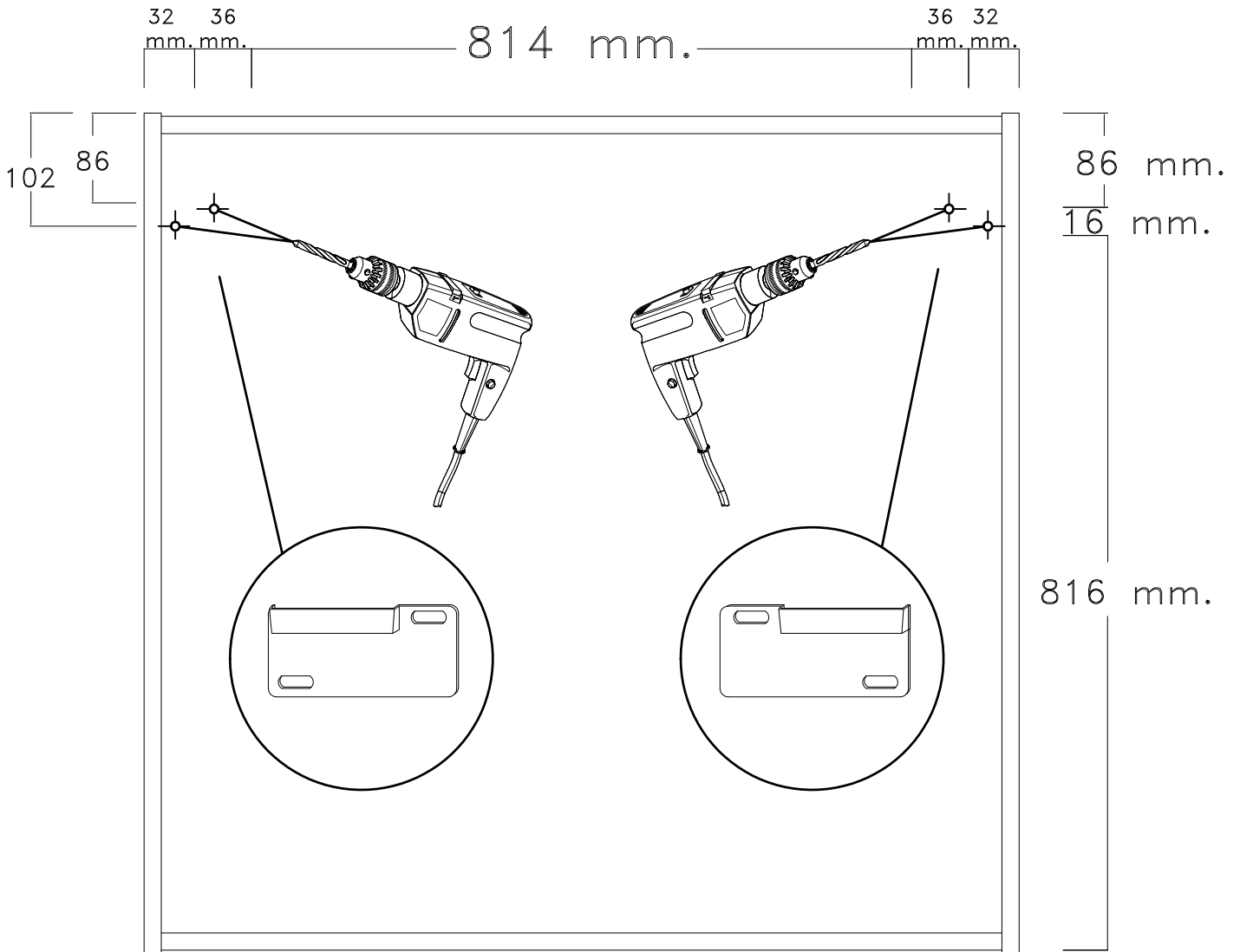

Cher client,
l'installation des meubles suspendus
doit être effectuée par un personnel compétent.
Les fischers ne sont pas inclus dans la quincaillerie.
Choisir les types des fischers pour le fixage apte au mur.
S'assurer de l'adéquation du mur pour support sûr du meuble

Dear Customer
The assembling of the hanging elements
must be done by a competent staff.
The fishers are not included in the hardware package.
Choose the fisher more suitable to the type of the wall.
Ensure the suitability of the wall for a
secure support of the hanging element.

Sehr geehrter Kunde, die Montage der Haengeelemente
muss von Fachpersonal ausgefuehrt werden!
Bitte verwenden Sie eigene, der Beschaffenheit der
Wand entsprechende Duebel.
Zu Ihrer eigenen Sicherheit legen wir dem
Beschlagbeutel keine Fischerduebel bei.

Gentile Cliente
Il montaggio dei pensili deve essere
effettuato da personale competente.
I tasselli di fissaggio non sono compresi nella ferramenta.
Scegliere il tipo di tassello per il fissaggio
più adatto alla tipologia di muro.
Assicurarsi l'idoneità della parete
per un sostegno sicuro del pensile.

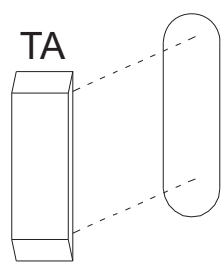
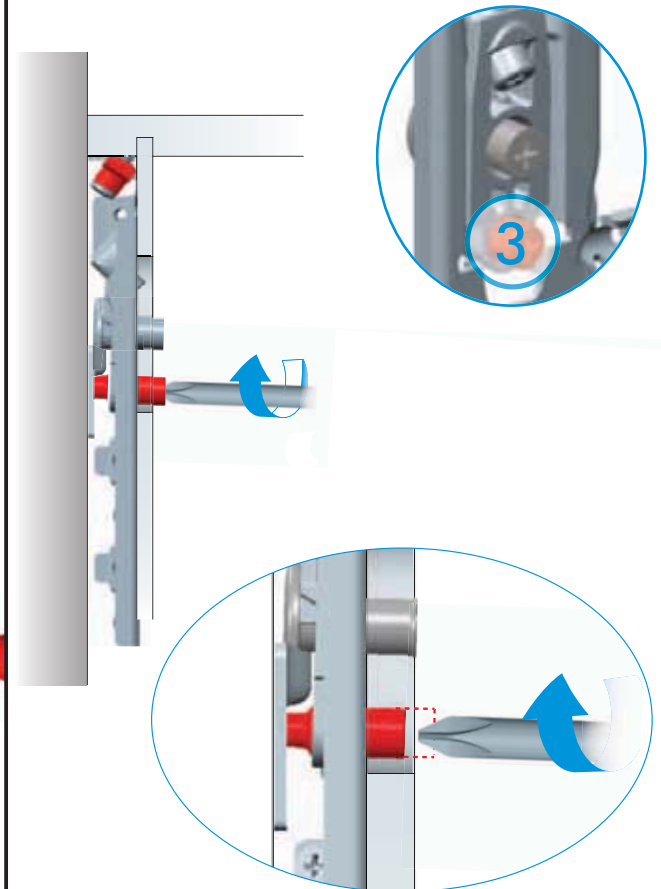
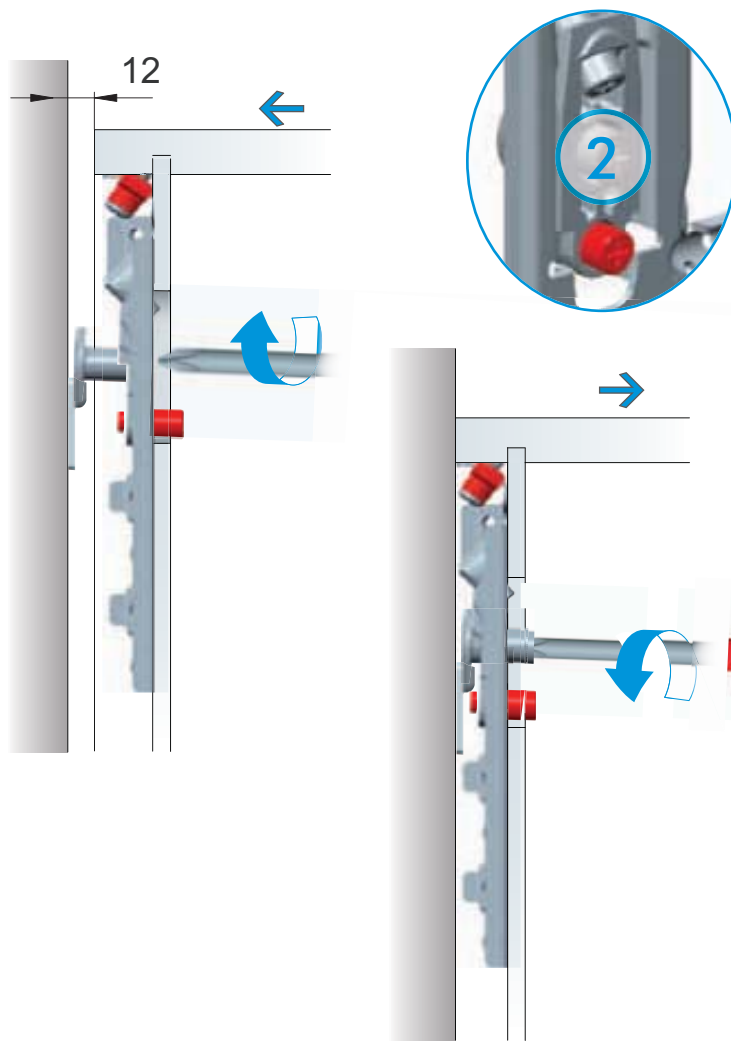
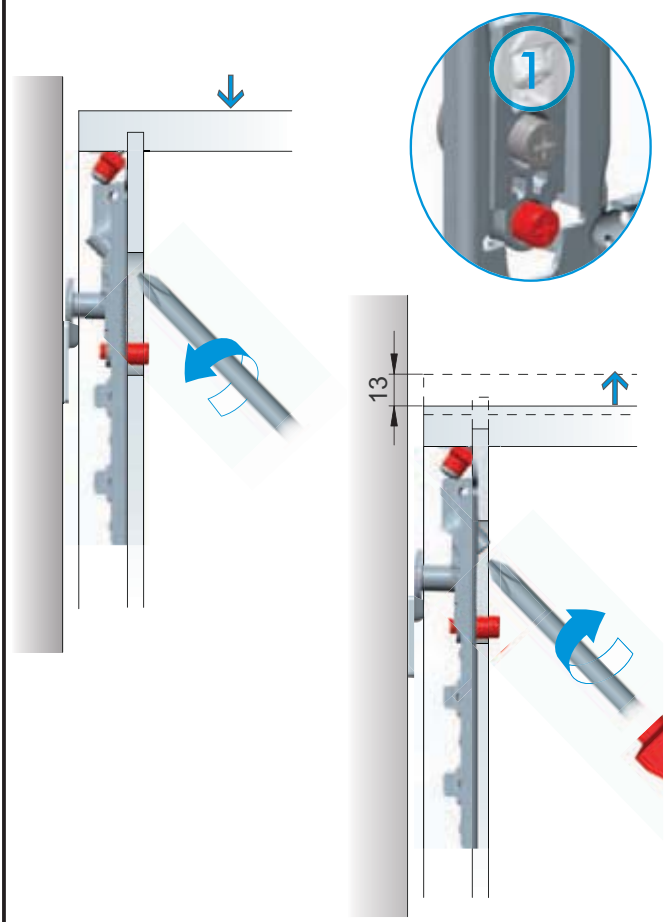
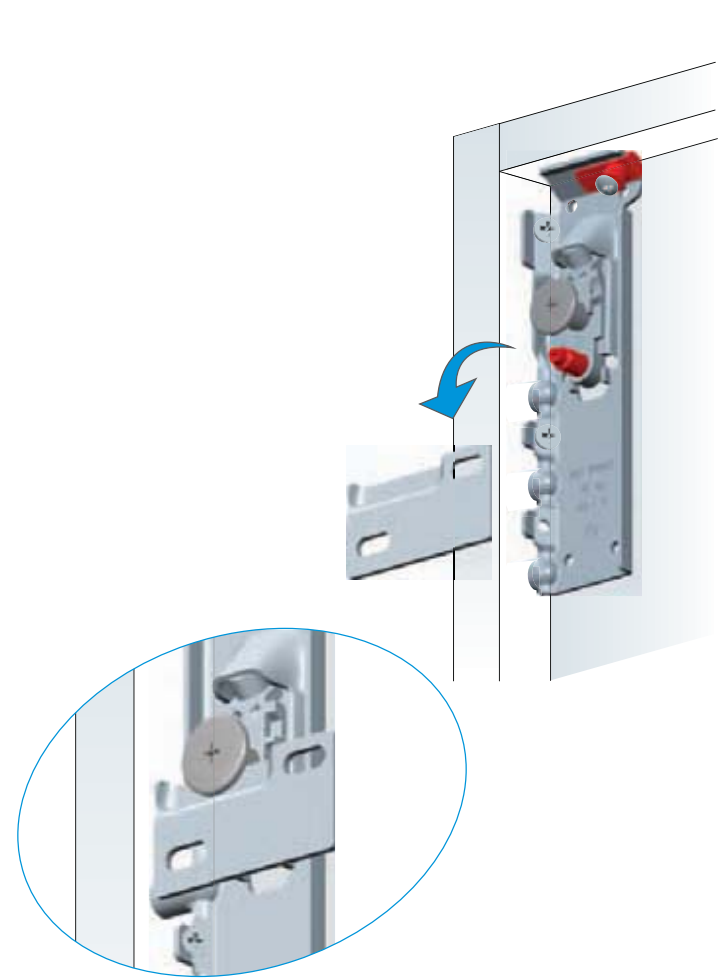

7

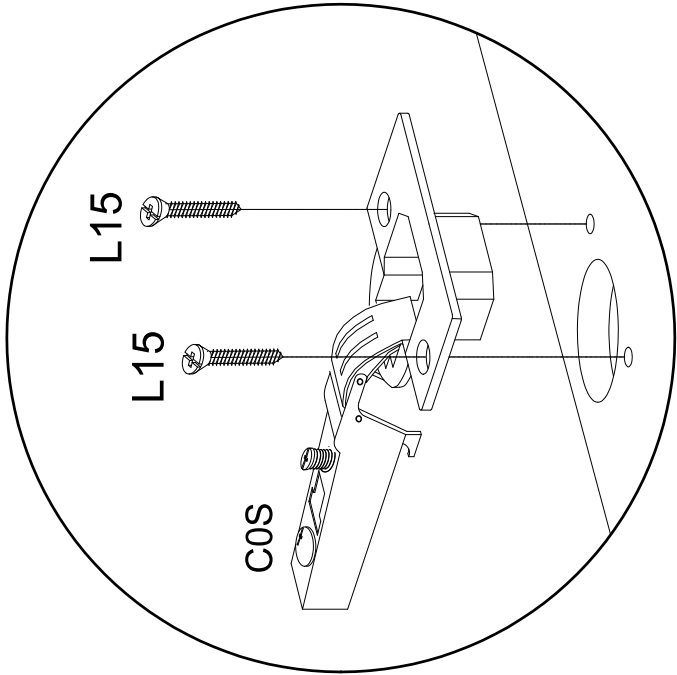

C0S

L15

P

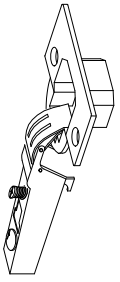

X4



4x15 mm.

X8



X4

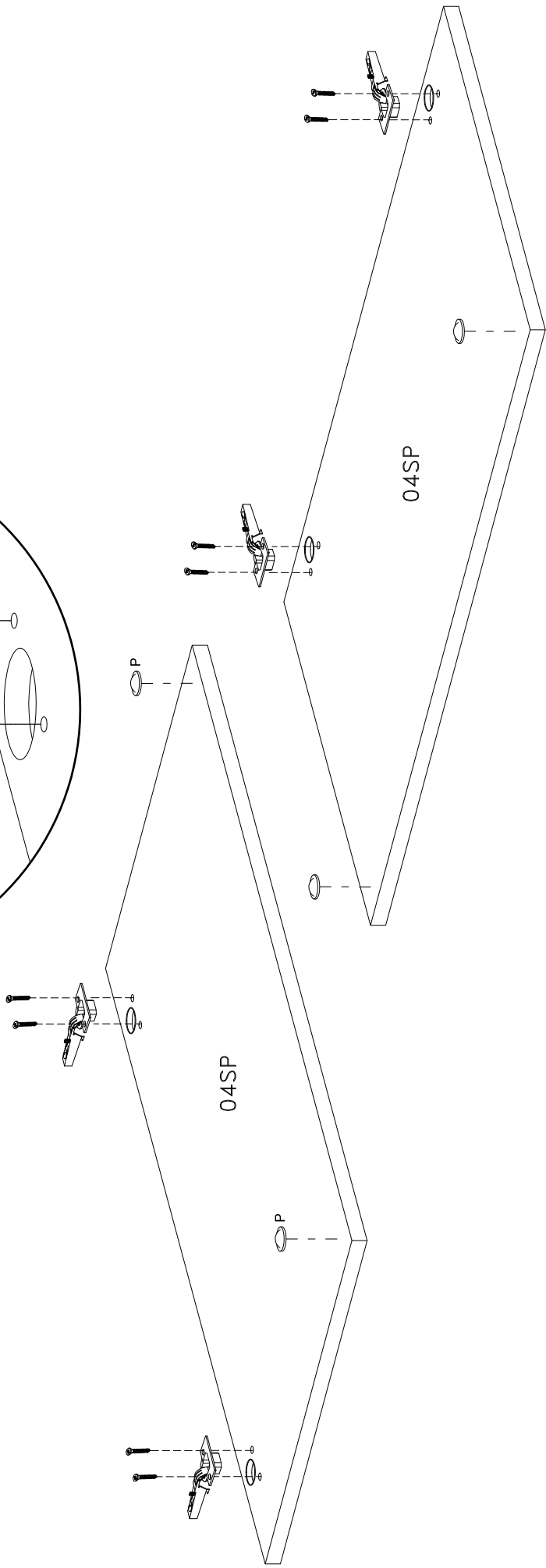

- C0S
- T1
- X4
- 4x10mm.
- L15
- T27
- X8
- 4x27,5mm.
- L418
- S6
- X8
- 32 mm.
- P14
- P
- X10
- X4

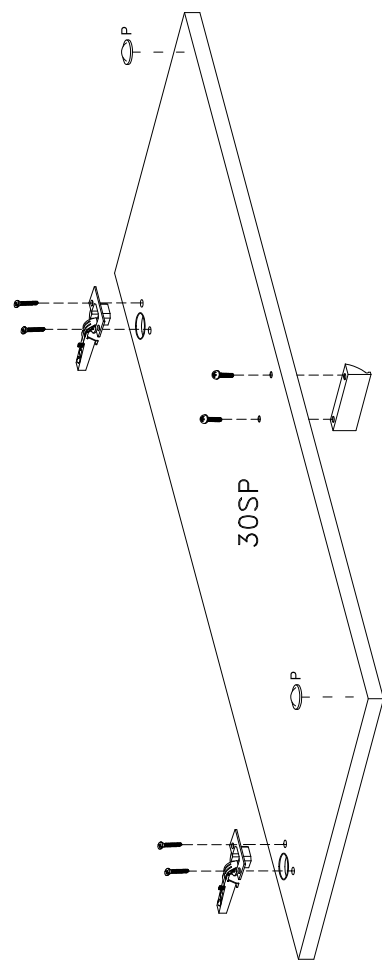
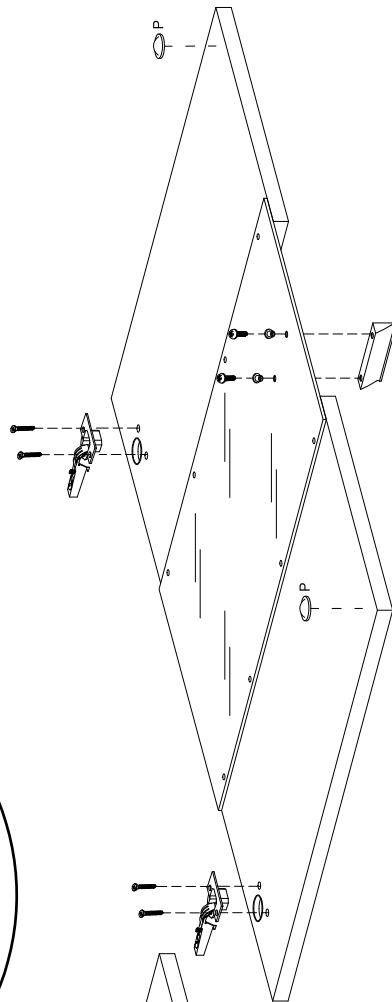
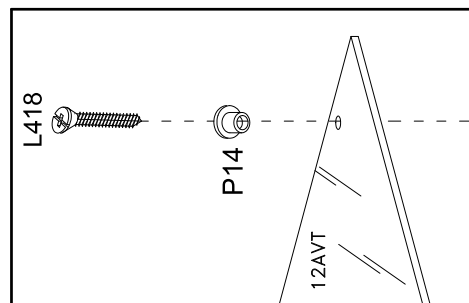
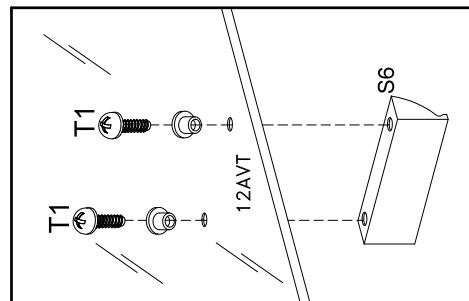
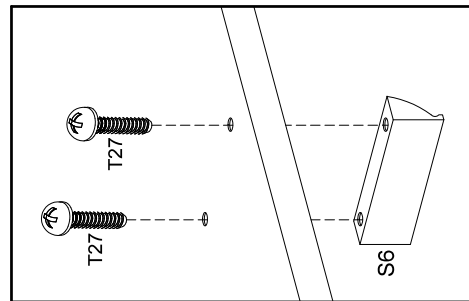
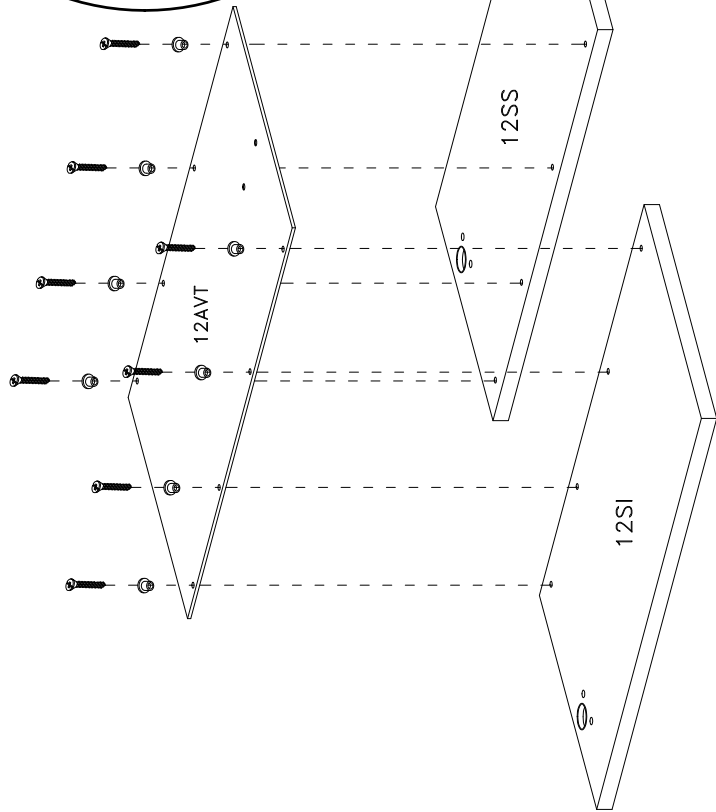
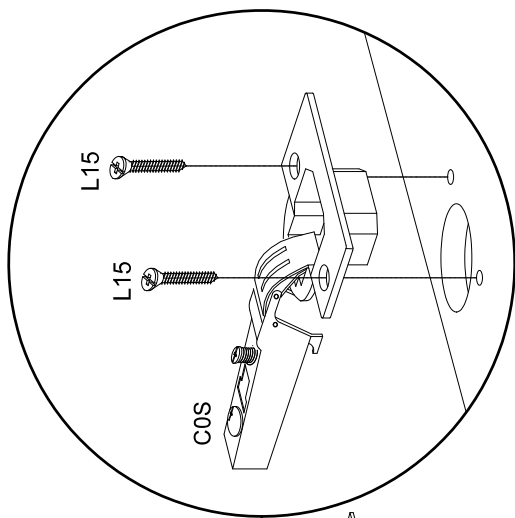

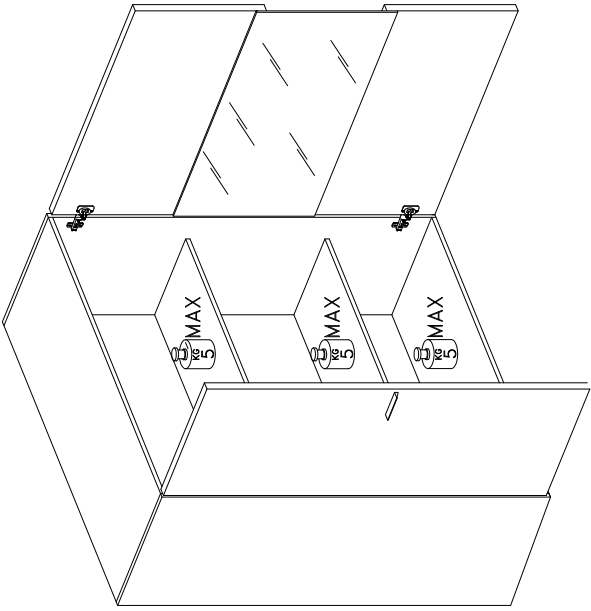
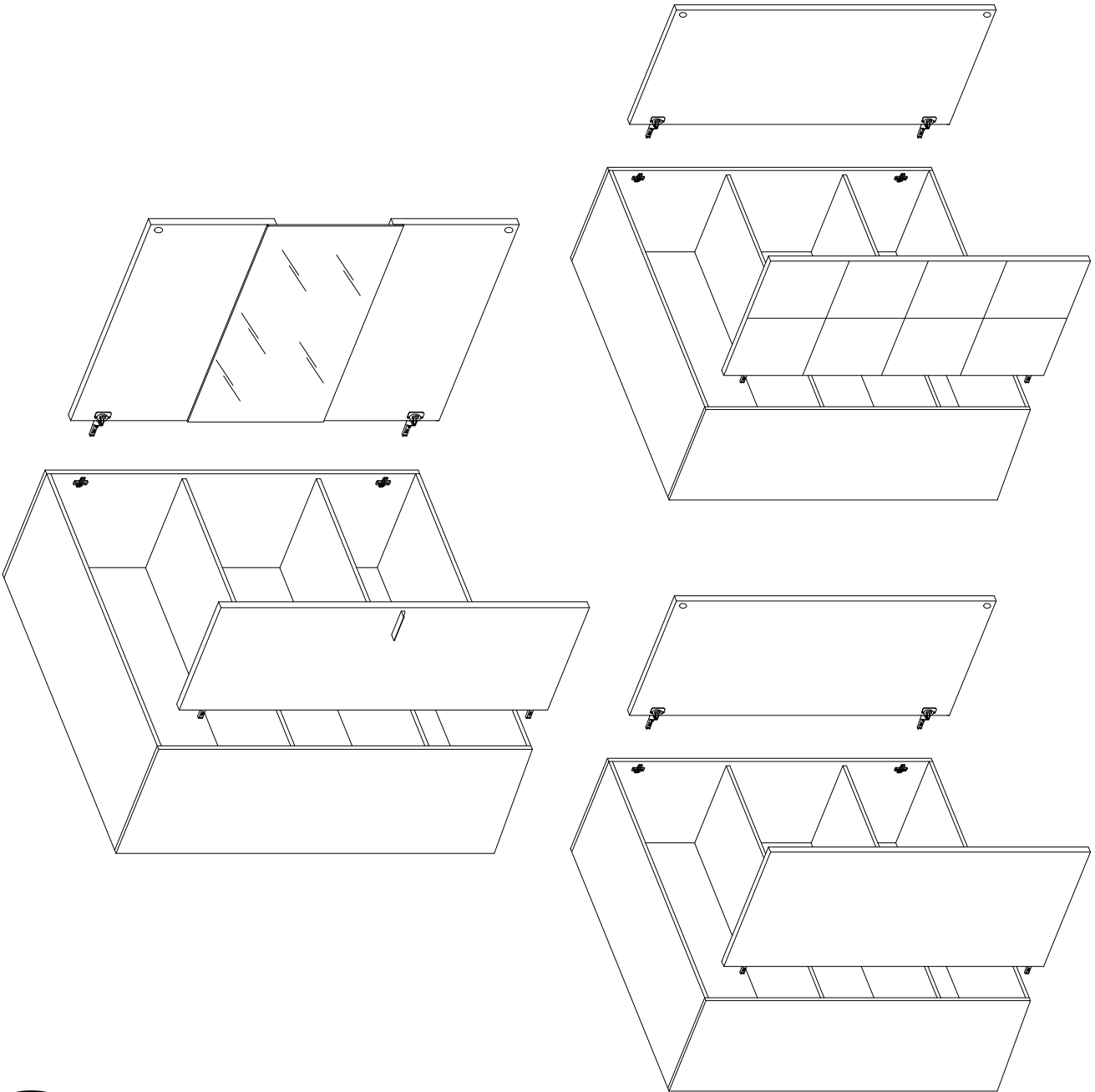

CLICK!!

