

Modellname / Model name / Nom du modele / Modellnamn / Nome modello / Název modelu / Modelnaam / Ime modela / Numéro Modelo / Modell neve / Название модели / Názov modelu / Ime modela / Denumire model / Наименование на модела / Nazwa modelu

CANBERRA

Modellnummer / Number / Numéro du modele / Numero / Номер на модела / modello / Číslo modelu / Modell száma / Eíslo modelu / Številka modela / Număr model / Broj modela / Modellnummer / Numer modelu

1139-318-59 □

Type / Tipo / Tipus / Тип / Тип / Tip

318

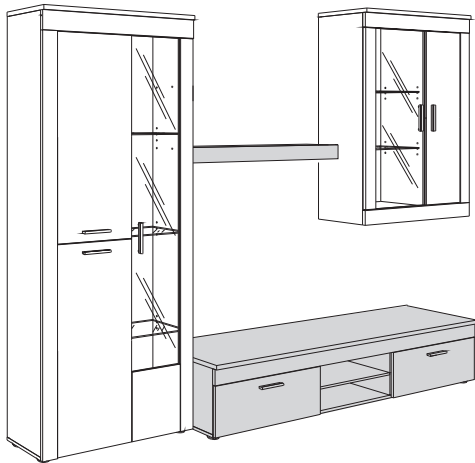
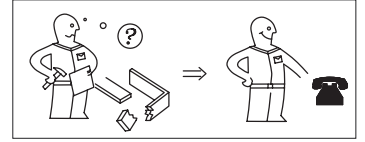
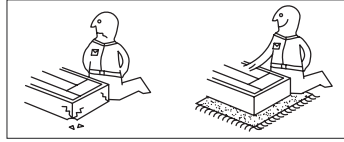
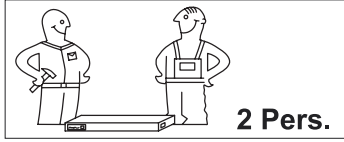

9A - 11A

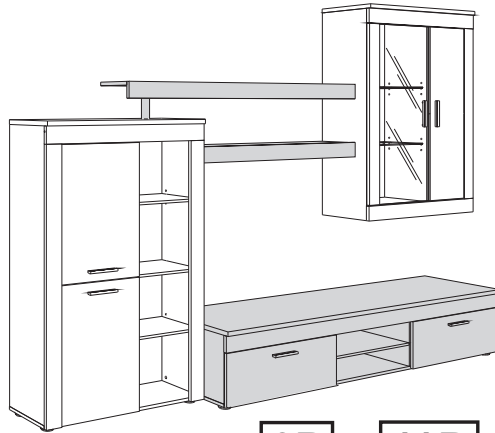

9B - 11B

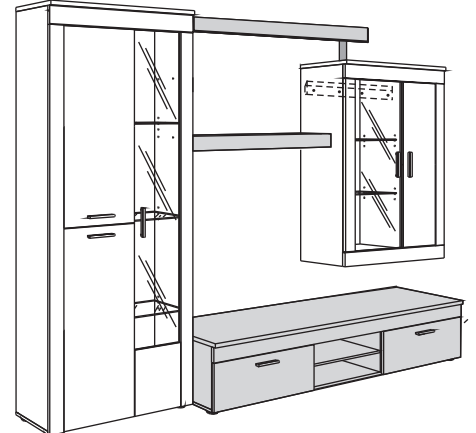

9C - 11C

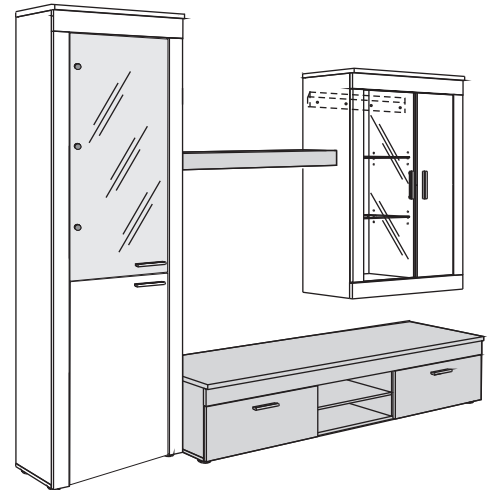
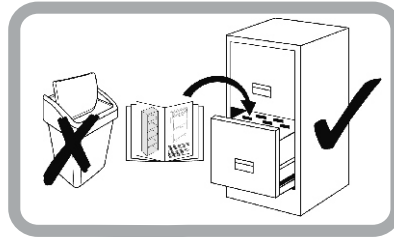
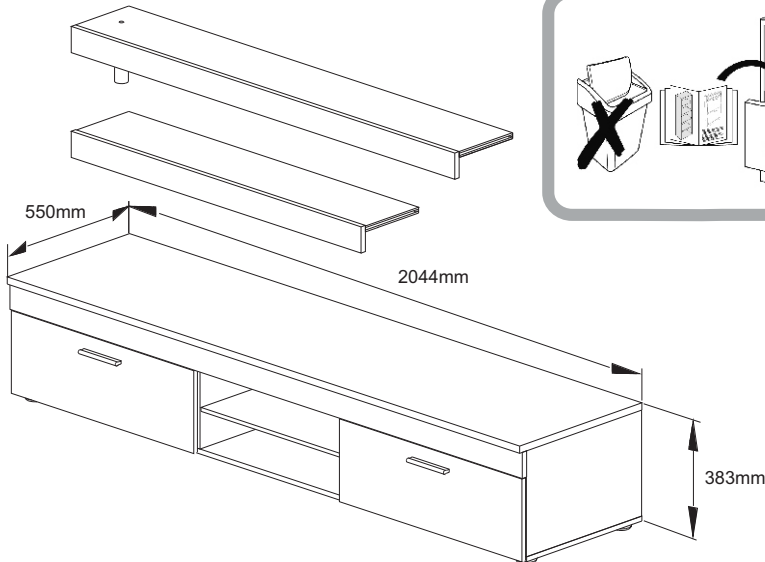

9D - 11D

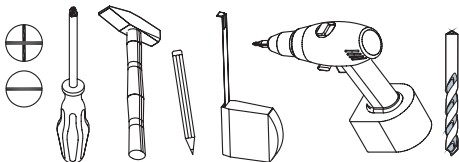

festziehen / tighten / Затягивать / serrer / stringere / utåhnut / vasttrekken / zategnuti / strångere / zwiázac / zacináč / szorosan meghúzni / pevne dotiahnut / trdno pritegniti / затянуть / dra ít



eindrücken / press in / enfoncer / wcisnąć / ribattere / zatlačit / Вкарайте / indrukken / benyomni / stlačit / vtisniti / tryck in / introducere prin apăsare / вдавить



ausmessen / measure / mesurer / misurare / opmeten / izmeriti / miara / kimérni / izmeriti / măsurare / измерить / změřit / Измерете / mät upp / zmierzyc



drücken / press / presser / stisknout / Натиснете / vtisniti / nasnac / drukken / pritisnuti / nacisnac / pritisniti / нажать / (meg)nyomni / apăsare / tryck fast / nacisnąć



einschlagen / hammer in / bevern / slå in / frapper au marteau / infossare / Zabit' / zarazit / Набийте / zabiti / wbić / introducere prin bătaie / забить / zatlouct



Drehen - wenden / przekrećić - odwrócić / Keren - omdraaien / Girare - Ruotare / Okrenuti - ubnuti / Retourner - renverser / Turn over - turn around / Otocte - obratite / Завъртете - обърнете / Obrnite list / Intoarceți - rotiți / Vrid runt - vänd / прокрутить - повернуть / otočit - obrátit / elforgatni - megfordítani

Modellname / Model name / Nom du modele / Modellnamn
Nome modello / Název modelu / Modelnaam / Ime modela
Número Modelo / Modell neve / Название модели /
Názov modelu / Ime modela / Denumire model /
Наименование на модела / Nazwa modelu

CANBERRA

Modellnummer / Number / Numéro du modele
Numero / Номер на модела / modello
Číslo modelu / Modell száma / Eíslo modelu
Številka modela / Număr model / Broj modela
Modelnummer / Numer modelu

1139-318-59

Type / Tipo / Tipus / Тип / Тип / Tip

318

D Unser Direktservice für Beschlagteile
Sollte Ihnen ein Beschlagteil fehlen, können Sie diese Servicekarte
direkt an die untenstehende Adresse mailen. Wir können allerdings
nur Beschlagteile auf diesem Wege verschicken. Sollten Sie eine
andere Beanstandung an Ihrem Möbelstück haben, so wenden sie
sich bitte direkt an Ihr Möbelhaus.

GB Our direct order service for fitting
If a fitting part is missing, you can e-mail this service card directly
to the address below. However, we can only send fitting parts in
this way. If you have any other cause for complaint concerning
your item of furniture, please contact your furniture store directly.

CZ Naše přímé služby pro kování
Chybí-li vám nějaký díl z kování, můžete tuto servisní kartu odeslat
e-mailem přímo na níže uvedenou adresu. Touto cestou však
můžeme rozeslat jen díly kování. Pokud byste reklamovali jiný díl
nábytku, obraťte se přímo na svého prodejce nábytku.

F Bien etudier la notice de montage
S'il vous manque une ferrure, veuillez envoyer directement la présente
carte service à l'adresse e-mail indiquée ci-dessous. Cependant, ceci
nous permet uniquement d'envoyer des ferrures. Pour tout autre type
de réclamation concernant votre meuble, veuillez contacter
directement votre magasin d'ameublement.

I Il nostro servizio diretto per l'ordine della ferramenta
Qualora Vi dovesse mancare un pezzo di fissaggio, allora Vi
preghiamo di inviare questa carta di servizio immediatamente
all'indirizzo sottostante. Possiamo inviare i pezzi di fissaggio
solamente per mezzo di questo procedimento. Qualora dovete
avere qualche altra reclamazione in merito al mobile, allora Vi
preghiamo di rivolgerVi direttamente al Vostro Negozio di mobili.

BG Нашата директна услуга за обков
Ако липсват части от комплекта, попълнете настоящата
сервисна карта и ни я изпратете на e-mail адреса, посочен
по-долу. По този начин можем да доставим само липсващи
елементи от обкова. Ако установите други дефекти по
мебелите, Ви съветваме да се обърнете към мебелната
къща/магазин, от който сте закупили стоката.

NL Onze directservice voor losse onderdelen
Wanneer er een onderdeel ontbreekt, kunt u deze servicekaart
direct aan onderstaand e-mailadres sturen. Wij kunnen langs deze
weg echter alleen beslagdelen versturen. Mocht u een ander
probleem aan uw meubel hebben, verzoeken wij u contact op te
nemen met uw meubeldealer.

PL Nasz bezpośredni serwis części montażowych
Jeżeli brakuje części koniecznych do montażu, prosimy o przesłanie
nam niniejszej karty serwisowej na niżej podany adres e-mailowy.
W ten sposób możemy przelać Państwu tylko brakujące części.
W przypadku innych reklamacji dotyczących mebla, prosimy zgłosić
się do salonu meblowego, w którym został dokonany zakup.

HR Servis za okove
U slučaju da nedostaje neki od dijelova molimo vas da na dolje
navedenu mail adresu pošaljete ovaj servisni obrazac. Na ovaj način
mogu se dostaviti samo okovi. U slučaju da imate dodatne prigovore
vezane uz komad namještaja molimo vas da se obratite izravno
trgovini namještaja gdje je isti kupljen.

HU Direktszolgálatunk vasalatok esetén
Ha hiányzik egy vasalat, ezt a kártyát közvetlenül elküldheti az
alább található címre. Azonban csakis vasalatoakat tudunk így
küldeni. Emellett másfajta reklamációt al fenn bútoráruház
illetően, forduljon közvetlenül a bútorházhöz.

SK Naš priamy servis pre časti kovania
Ak by Vám chýbala nejaká časť kovania, môžete poslať
túto servisnú kartu poslať e-mailom na nižšie uvedené
adresu. Díly kovania vieme poslať iba týmto spôsobom.
Ak by ste mali inú reklamáciu ohľadom Vášho nábytku,
obraťte sa priamo na Vašu predajňu nábytku.

SLO Naše direktne uslužne storitve za okovje
Če vam manjka kakšno okovje, lahko to servisno kartico pošljete
po e-pošti direktno na spodnji naslov. Po tej poti vam lahko
pošljemo samo okovje. Če želite reklamirati kakšen drug del
pohištva, se obrnite neposredno na vašo trgovino pohištva.

RO Service-ul nostru direct pentru feronerie
În cazul în care vă lipsește o piesă de feronerie puteți să trimiteți
direct acest card de service prin e-mail la adresa de mai jos. Noi
nu putem expedia piese de feronerie decât pe această cale.
Dacă aveți o altă reclamație referitoare la piesa de mobilier,
atunci vă rugăm să vă adresați direct la magazinul dvs. de mobilă.

RUS Наш прямой сервис для поставок фурнитуры
Если окажется, что Вам не хватает того или иного элемента
фурнитуры, Вы можете отправить сервисную карту по факсу
непосредственно на нижеприведенный адрес электронной
почты. Однако, таким образом мы можем пересылать лишь
фурнитуру. Если же у Вас возникнут иные претензии относительно
приобретенной мебели, пожалуйста, обращайтесь
непосредственно в организацию, осуществившую продажу.

S Vår directservice för beslagsdelar
Om du saknar en beslagsdel kan du skicka detta servicekort direkt
till e-postadressen som anges nedan. Tänk på att detta är den enda
möjligheten att skicka beslagsdelar till dig. Om du vill reklamera din
möbel av en annan anledning måste du kontakta ditt möbelhus direkt.

ES Nuestro servicio directo para accesorios
Si le falta algún accesorio, puede enviar esta tarjeta de servicio directamente
a la siguiente dirección. No obstante, por este método solo podemos
enviar accesorios. Si tiene alguna otra objeción sobre su mueble, consulte
directamente con su mueblería.

TR Donatılar için doğrudan servisimiz
Bir donatınız eksikse bu servis kartını doğrudan aşağıda bulunan adrese
doğrudan mail yazabilirsiniz. Sadece bu yolla donatıları gönderebiliriz.
Mobilyanızda başka şikayetleriniz varsa lütfen doğrudan mobilya satıcınıza
danışın.

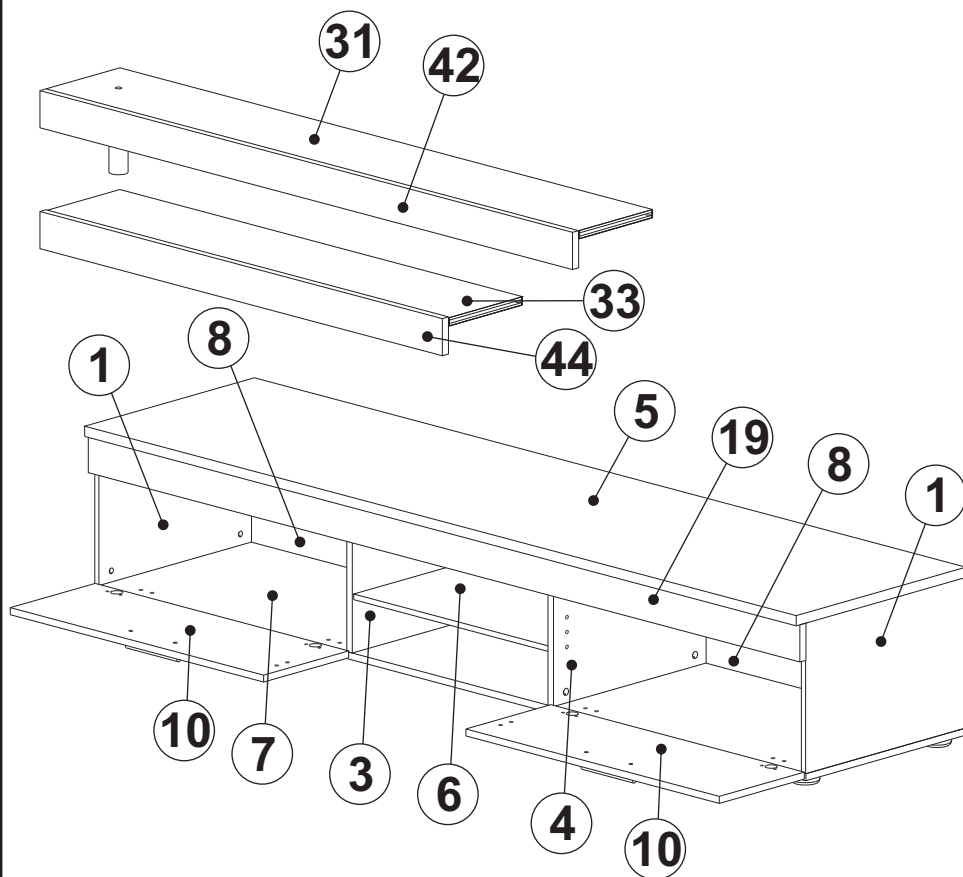
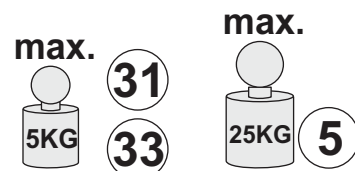

Grund der Beanstandung / Reason of the objection:

Möbelhaus / Furniture store:

Name / Nom:

Telefon / Telephone:

PLZ / Bank sorting code:

Ort / City:

Strasse / Street:

Haus-Nr. / House No.:

@E-Mail:

Modellname / Model name / Nom du modele / Modellnamn
Nome modello / Název modelu / Modelnaam / Ime modela
Numéro Modello / Modell neve / Название модели /
Názov modelu / Ime modela / Denumire model /
Наименование на модела / Nazwa modelu

CANBERRA

Modellnummer / Number / Numéro du modele
Numero / Номер на модела / modello
Číslo modelu / Modell száma / Eíslo modelu
Številka modela / Număr model / Broj modela
Modelnummer / Numer modelu

1139-318-59

Type / Tipo / Típus / Тип / Тип / Тип

318

B11

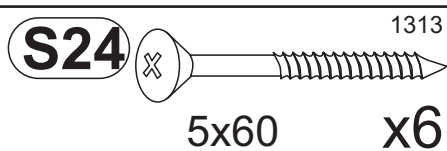
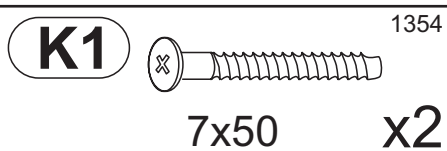
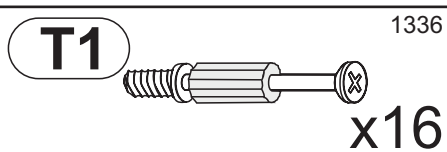
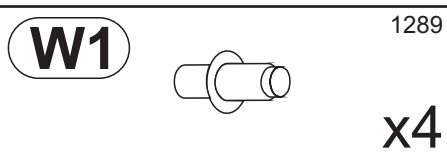
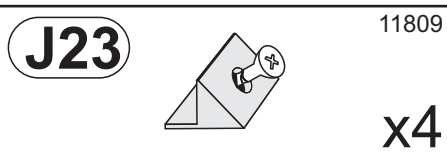
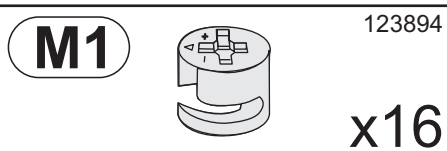
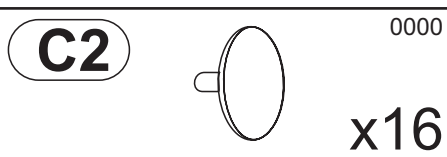
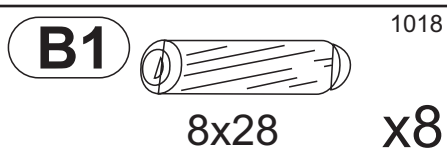

B12

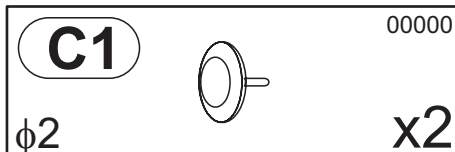
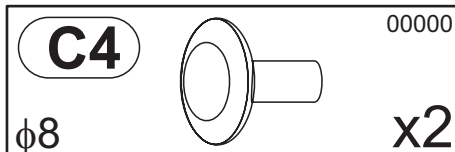
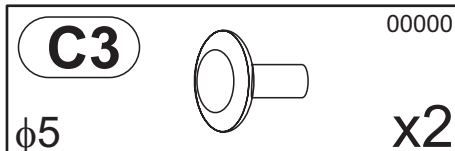
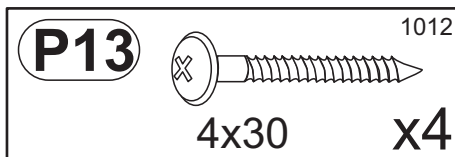
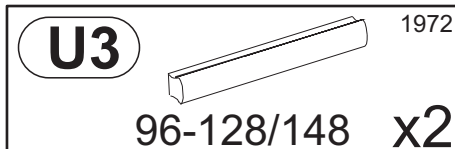

B13

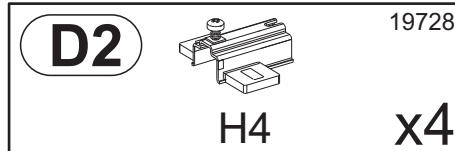
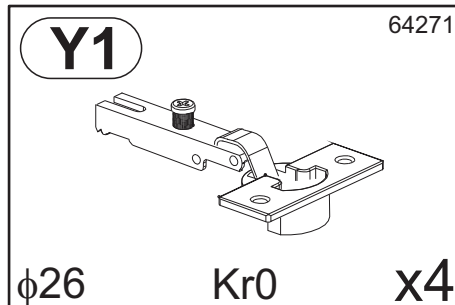

B15

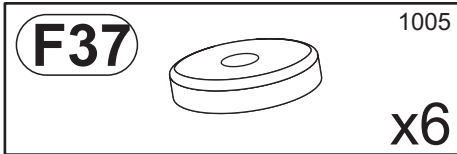
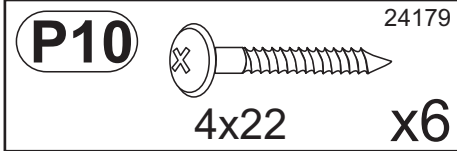

B17

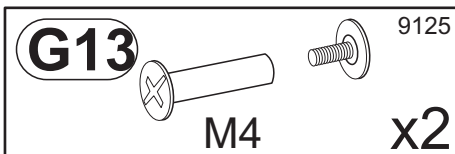
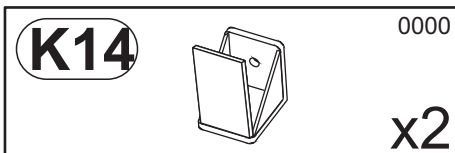
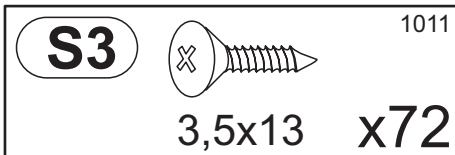
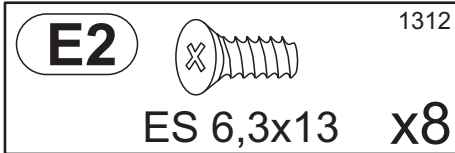
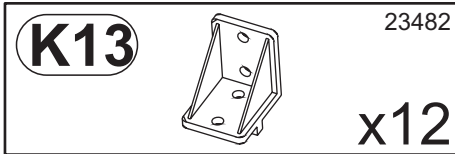
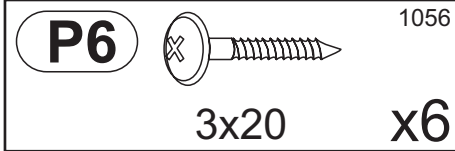

B20

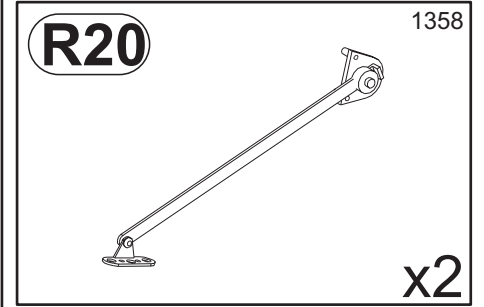
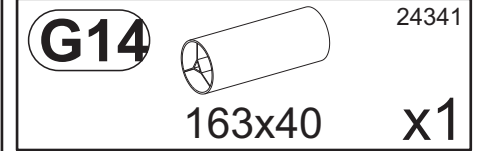

1

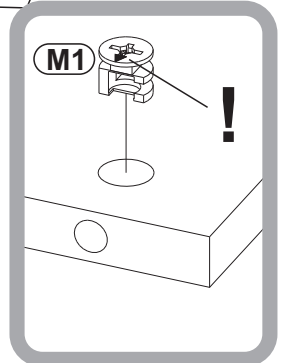
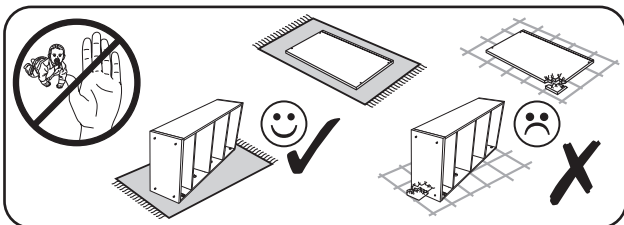
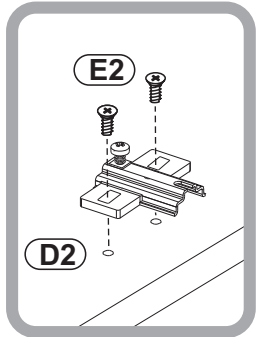
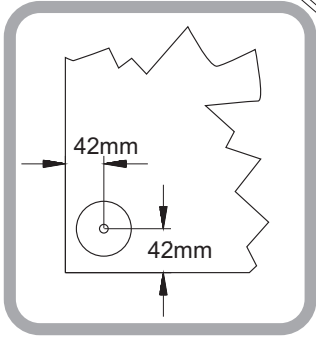
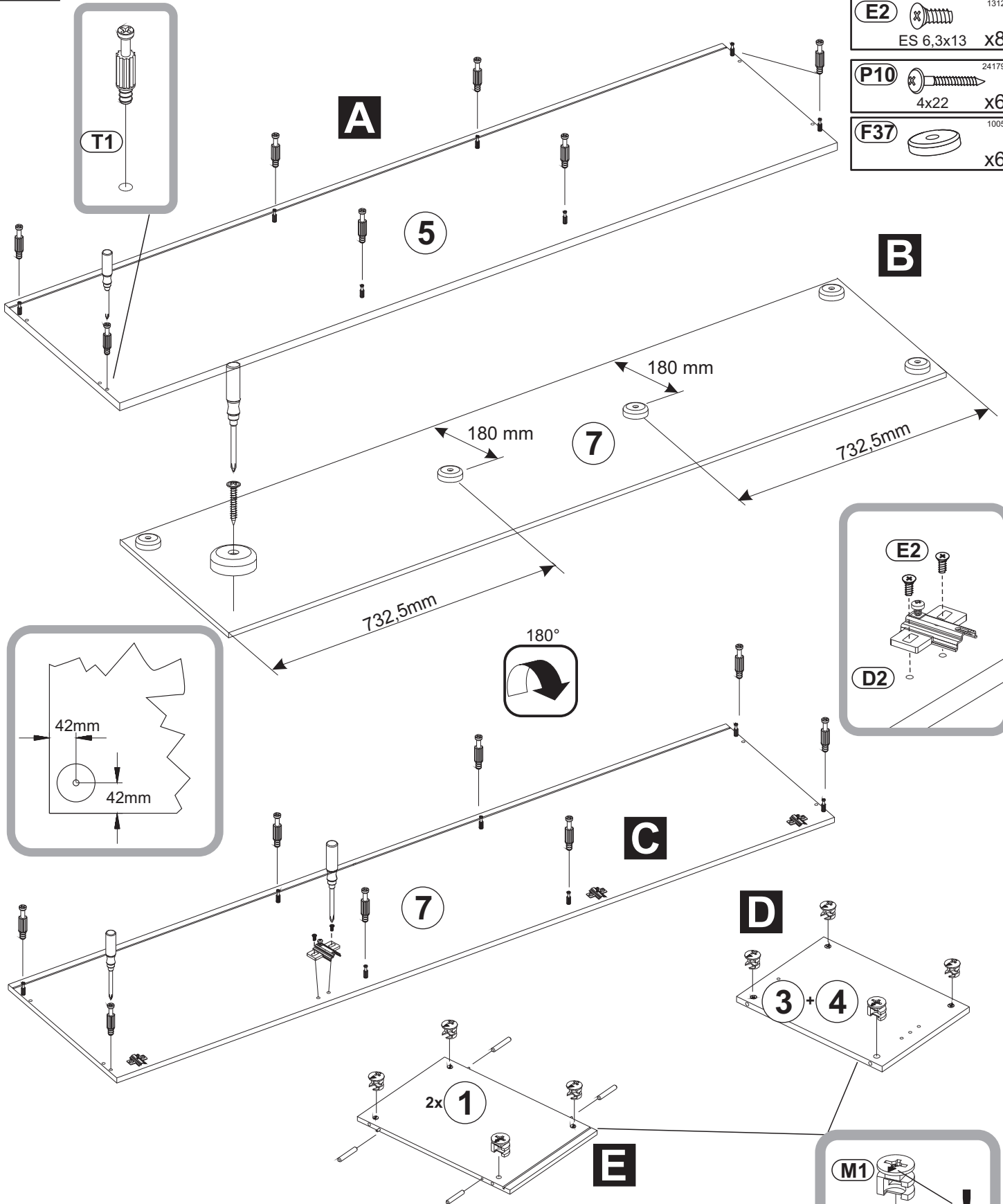
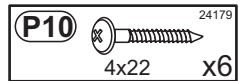
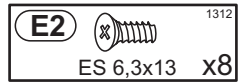
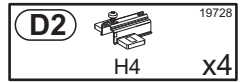
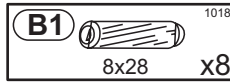
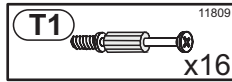
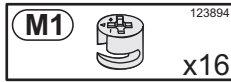

2

(K13)  23482
x5

(S3)  1011
3,5x13 x10

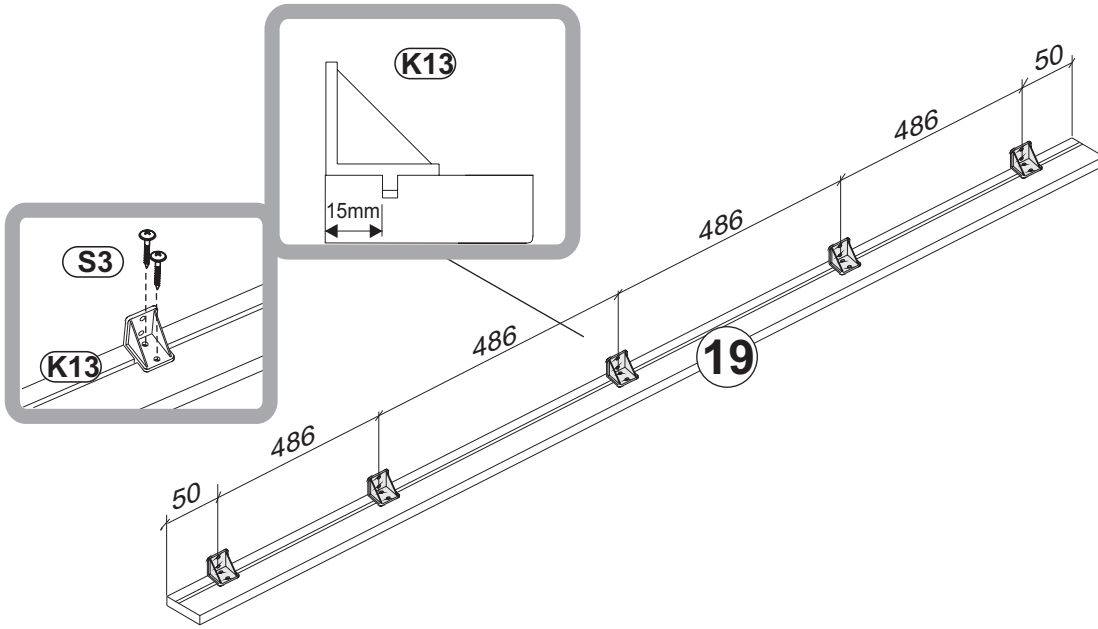

3

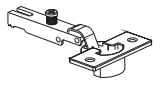
(Y1)  64271
φ26 Kr0 x4

(S3)  1011
3,5x13 x14

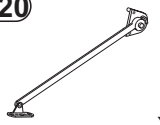
(R20)  1358
x2

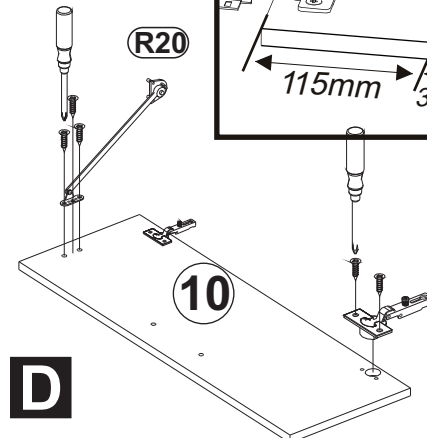
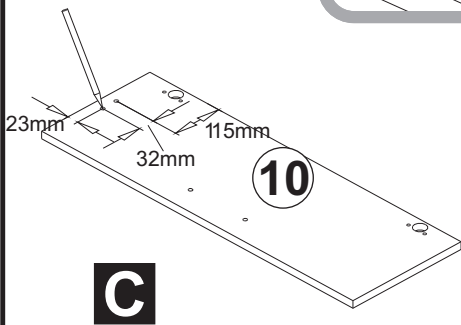
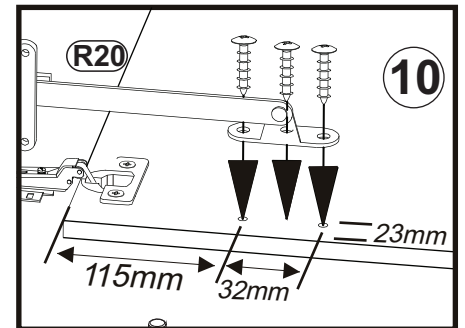
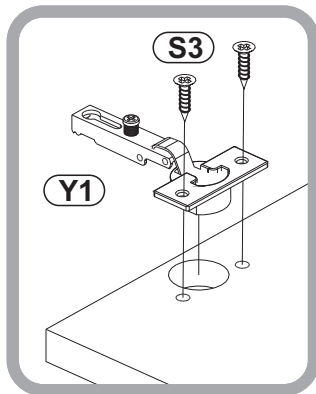
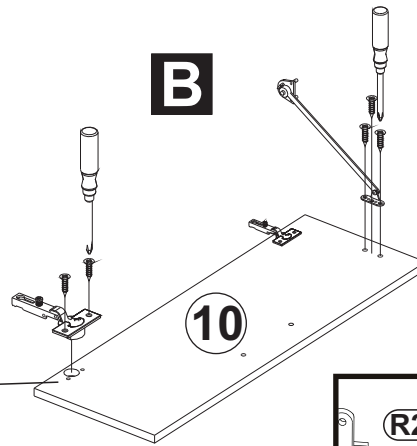
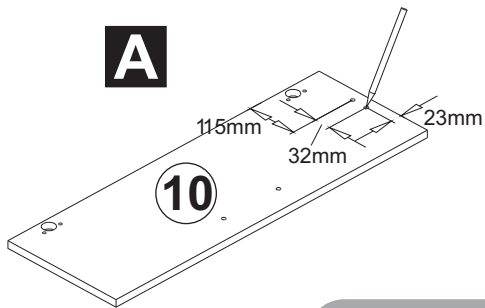

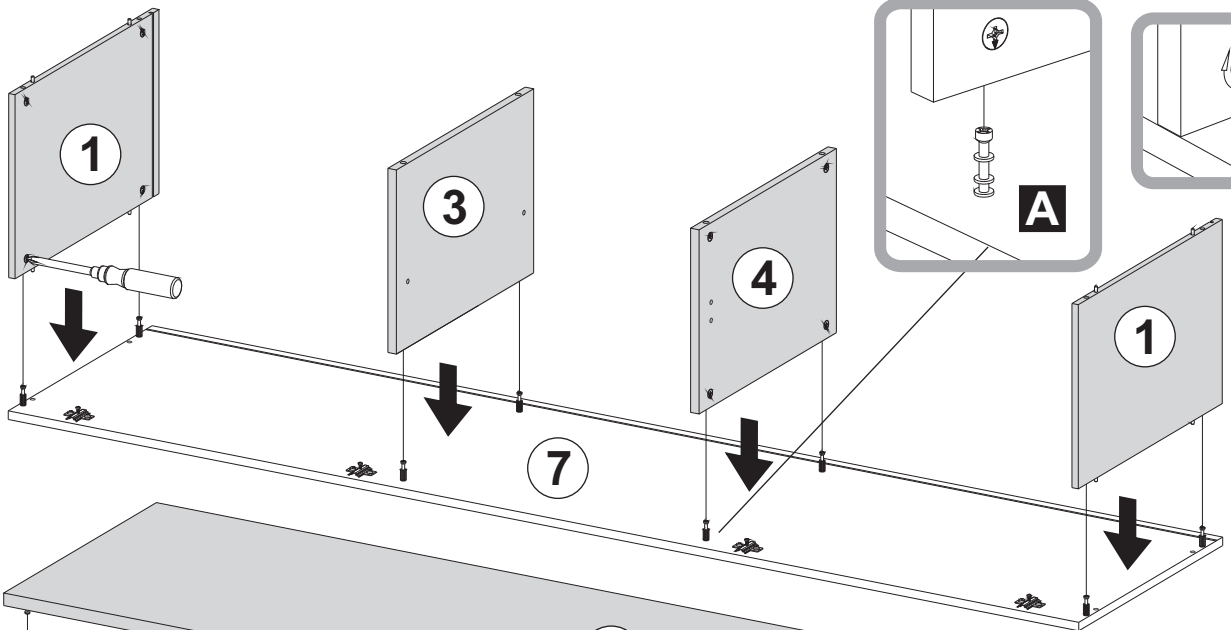
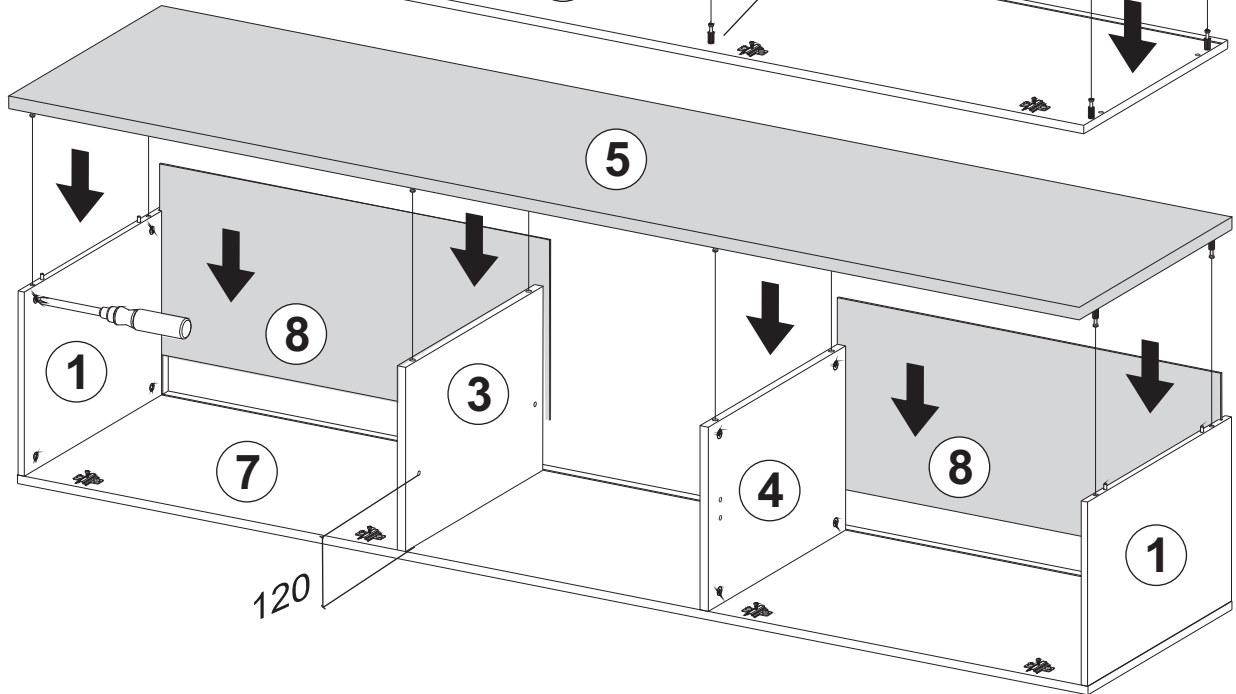
4**A****B****5**

J23  1302 x4

P6  1056 3x20 x6

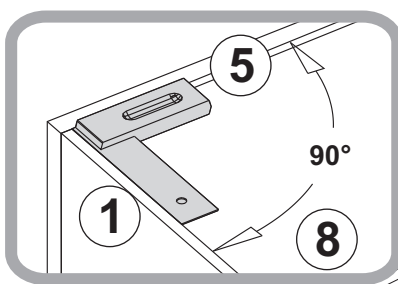
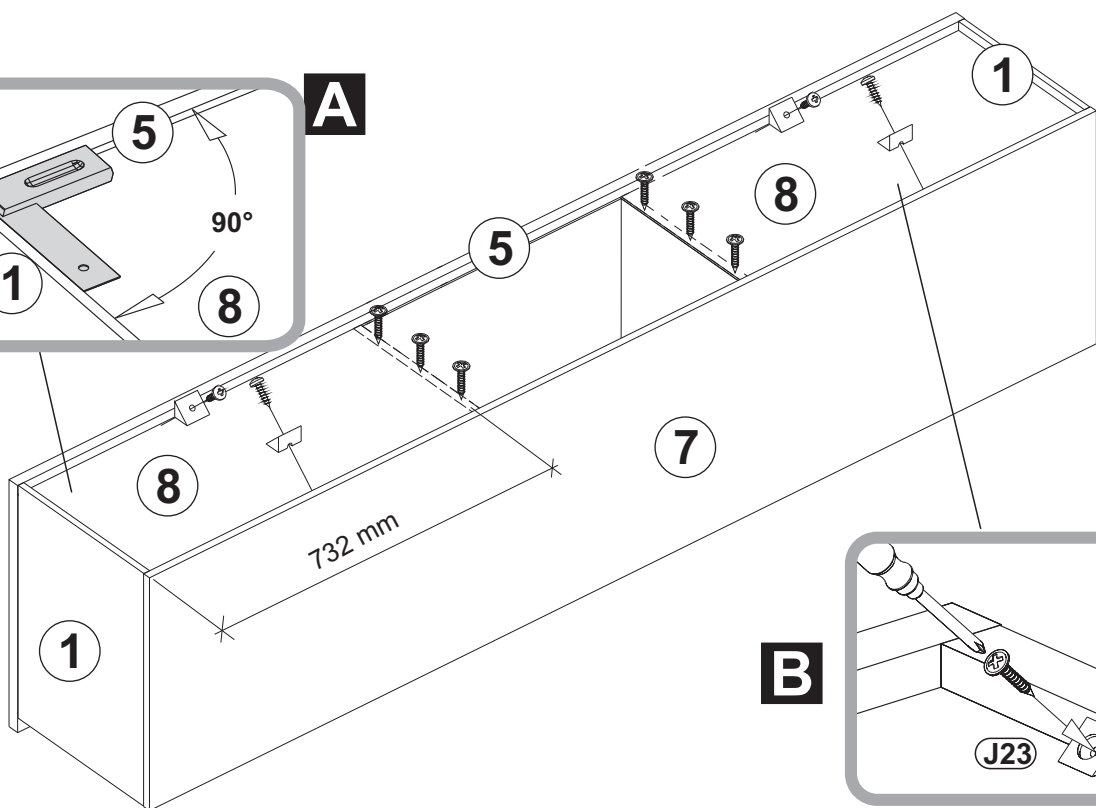
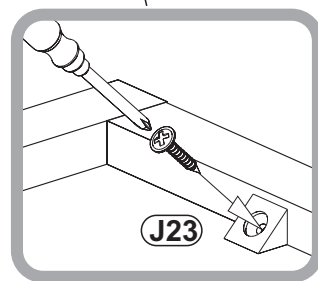
**A****B**

6



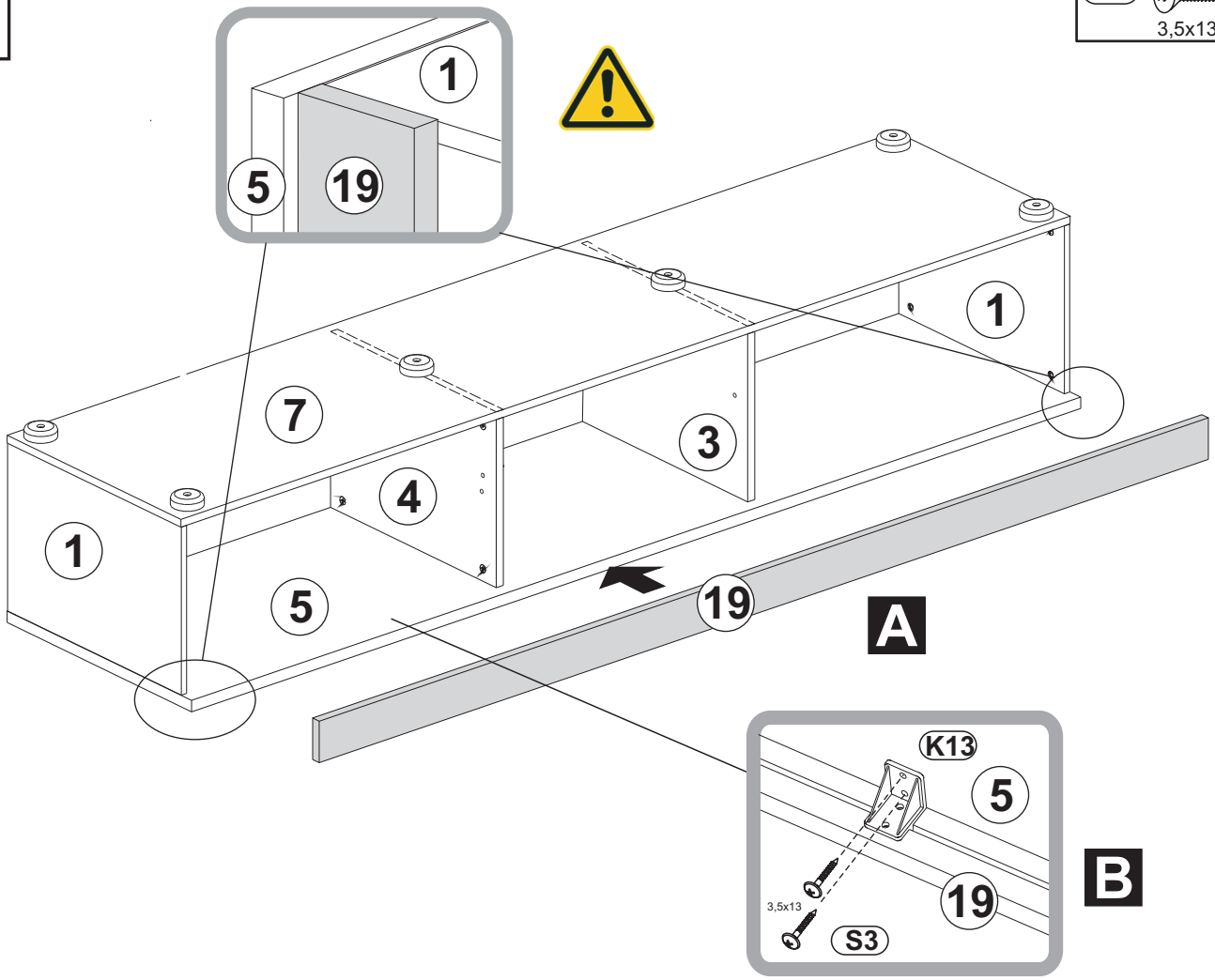

S3 1011
3,5x13 x10

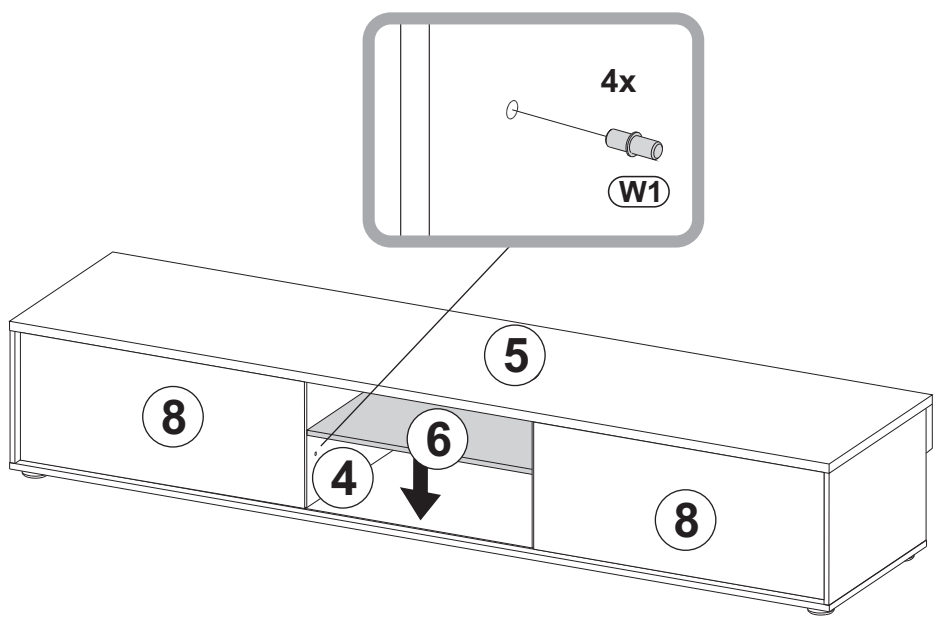

7

W1 1289
x4



| | | |
|------------|---|-------|
| K1 |  | 1354 |
| | 7x50 | x1 |
| G14 |  | 24341 |
| | 163x40 | x1 |
| K13 |  | 23482 |
| | | x7 |
| S3 |  | 1011 |
| | 3,5x13 | x14 |

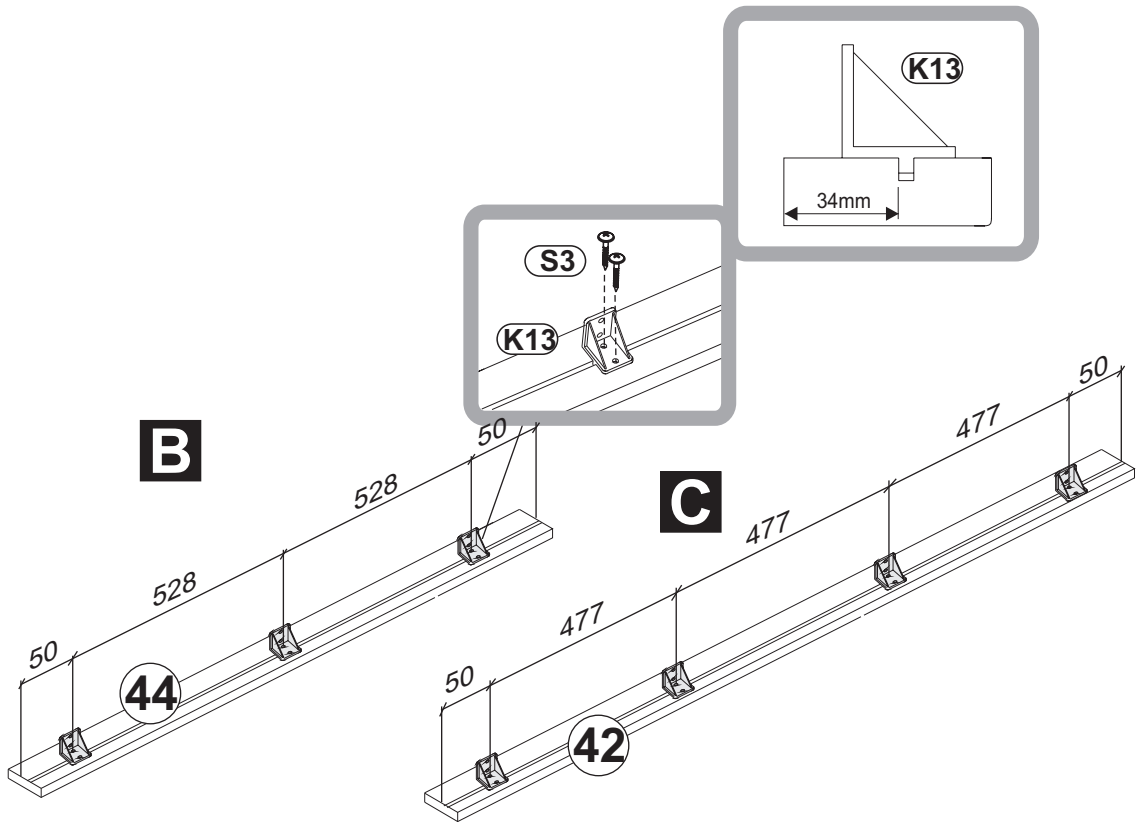
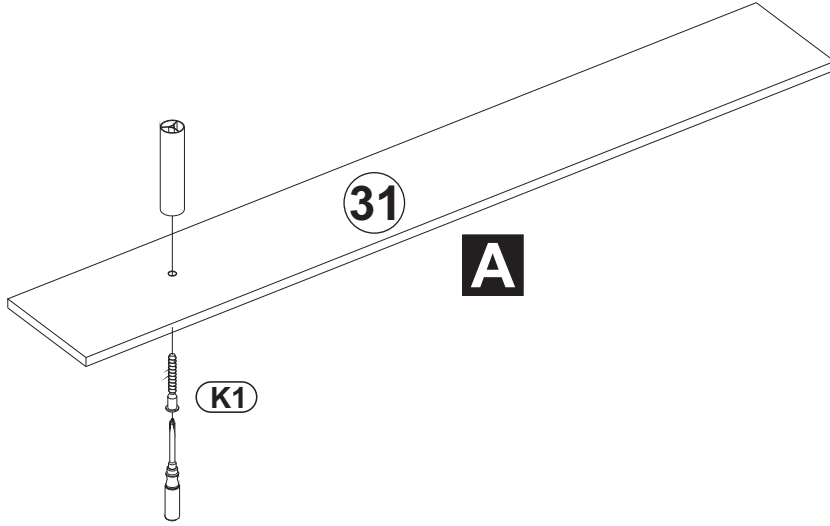

9A

S3  1011
3,5x13 x6

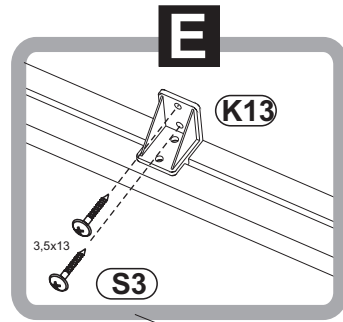
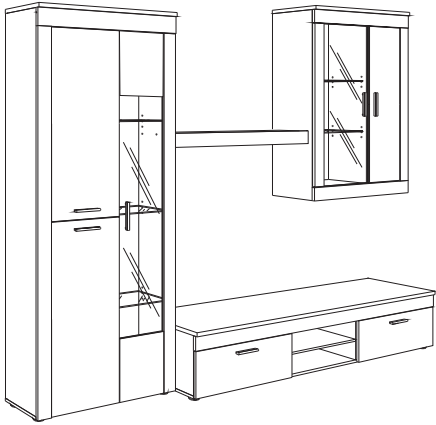

B

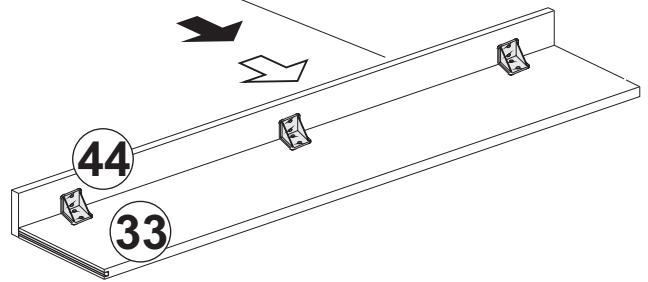

C

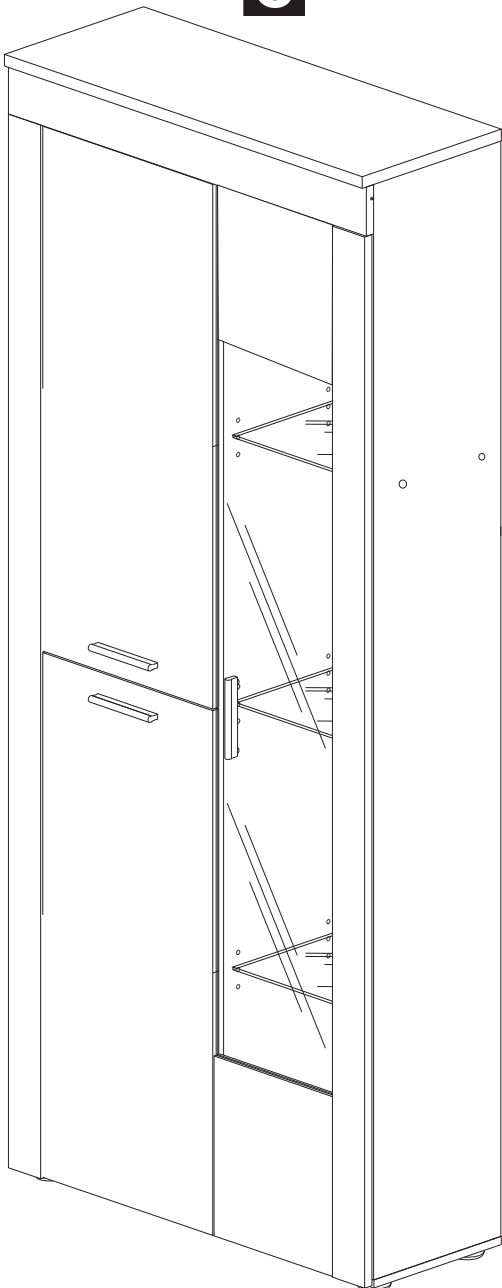

D

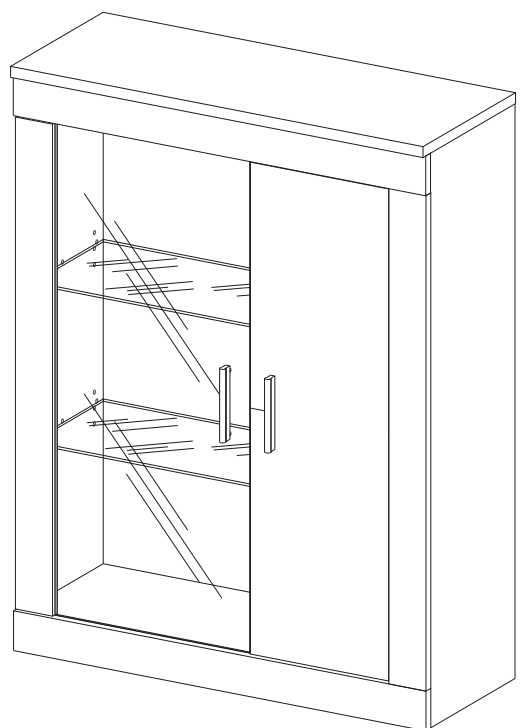

10A

G13 9125
M4 x2

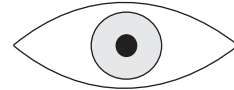

12A

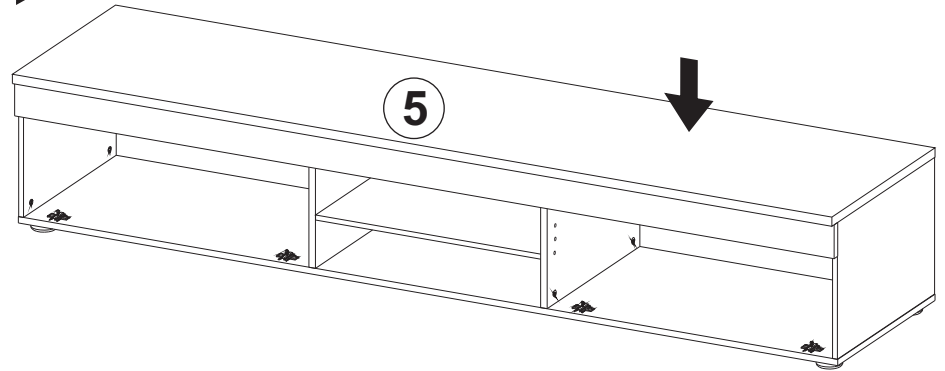
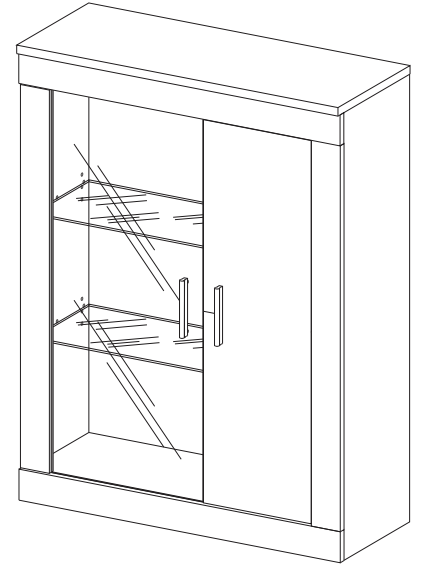
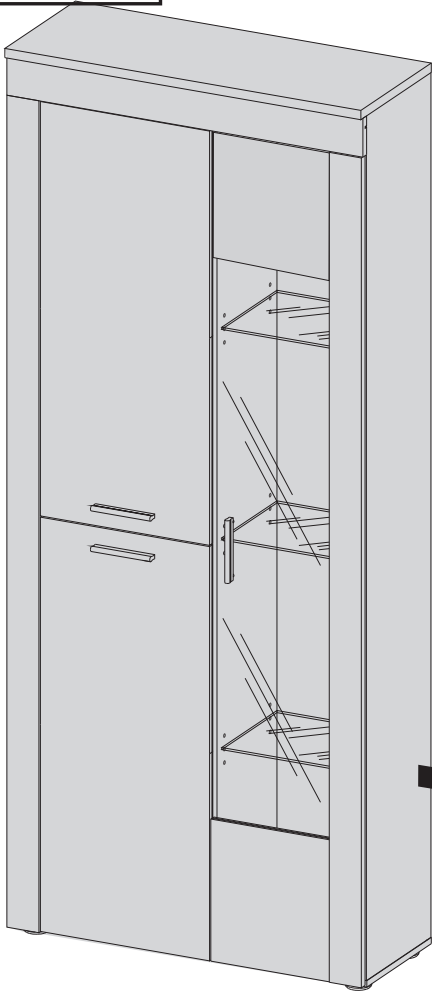

A

2x

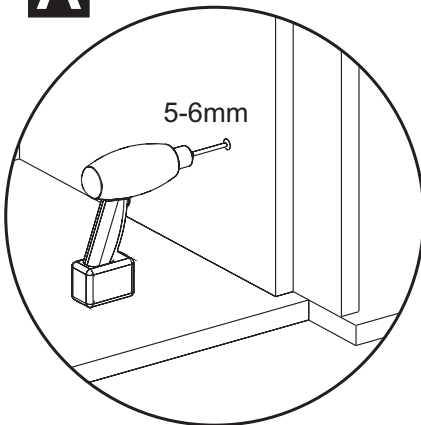

B

2x

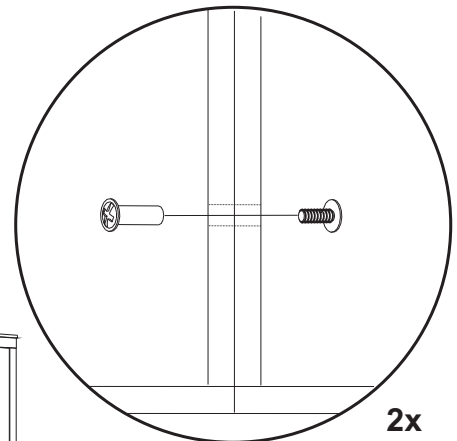
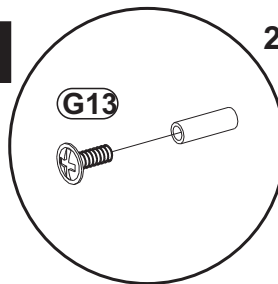

2x

C

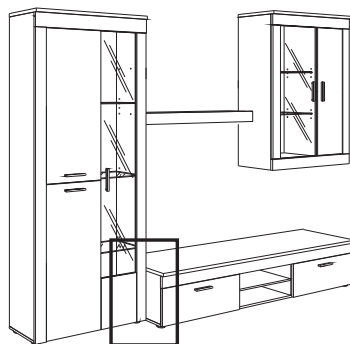

11A

1 Schritt

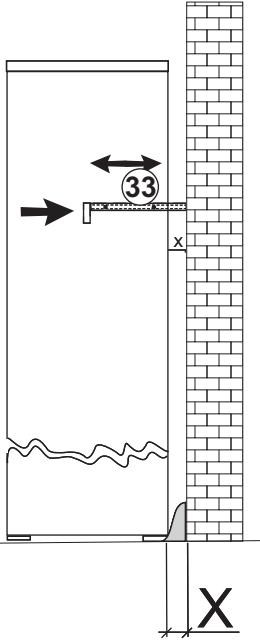

2 Schritt

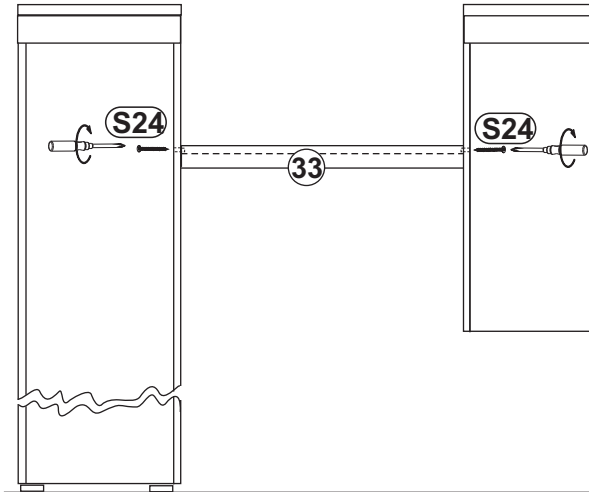

| | | |
|------------|--|-------|
| C1 | | 00000 |
| φ2 | | x2 |
| C4 | | 00000 |
| φ8 | | x2 |
| C3 | | 00000 |
| φ5 | | x2 |
| C1 | | 00000 |
| φ2 | | x2 |
| S24 | | 1313 |
| 5x60 | | x4 |
| S3 | | 1011 |
| 3,5x13 | | x6 |
| U3 | | 1972 |
| 96-128/148 | | x2 |
| P13 | | 1012 |
| 4x30 | | x4 |

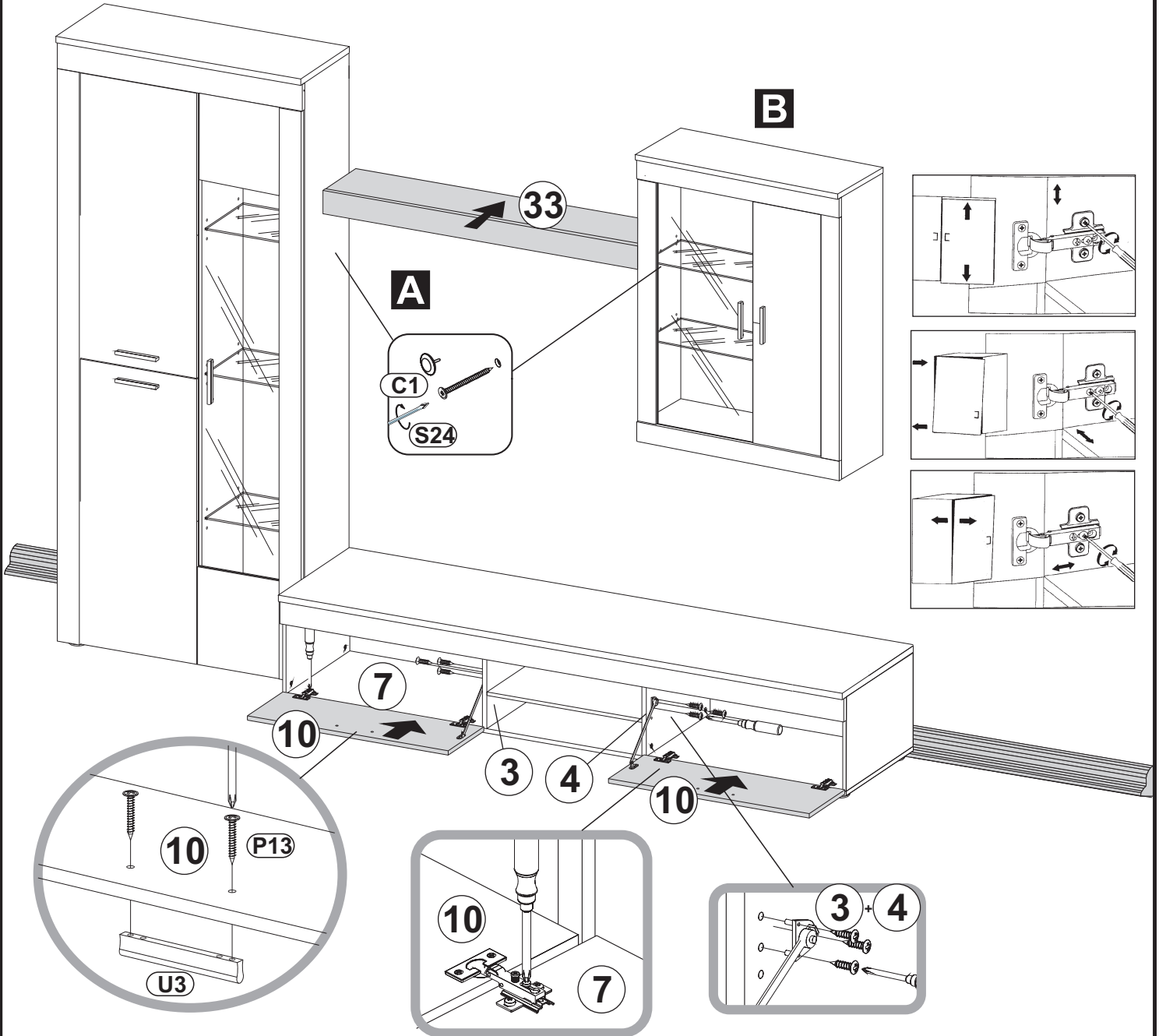

9B

S3  1011
3,5x13 x14

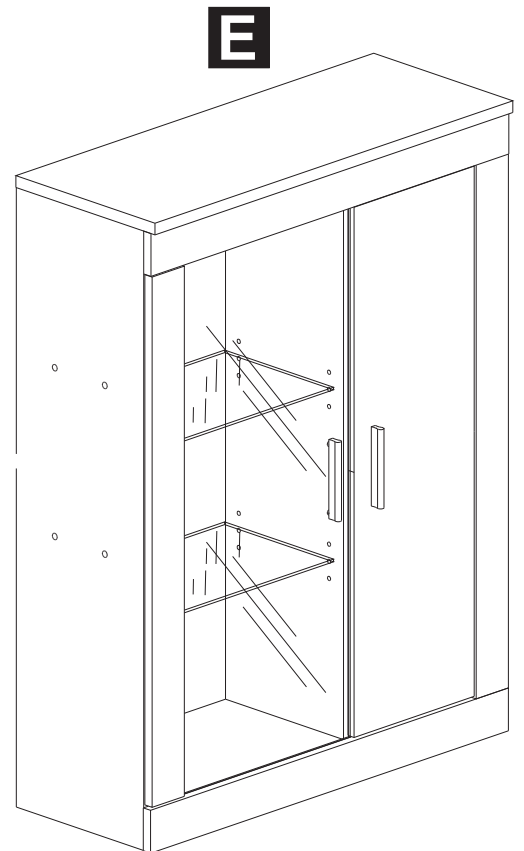
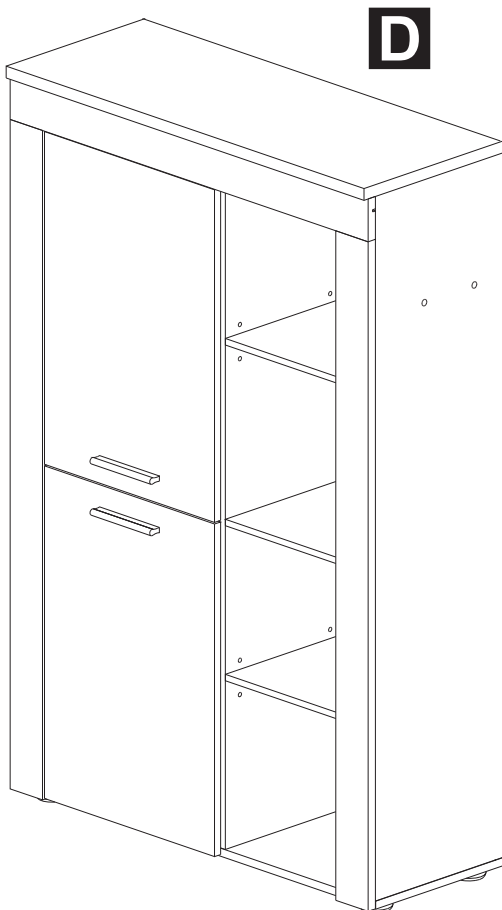
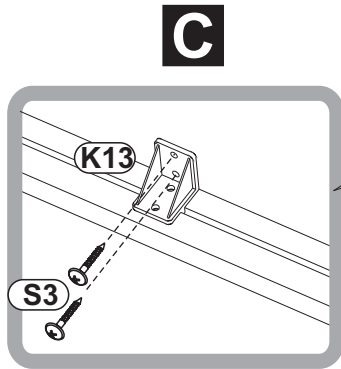
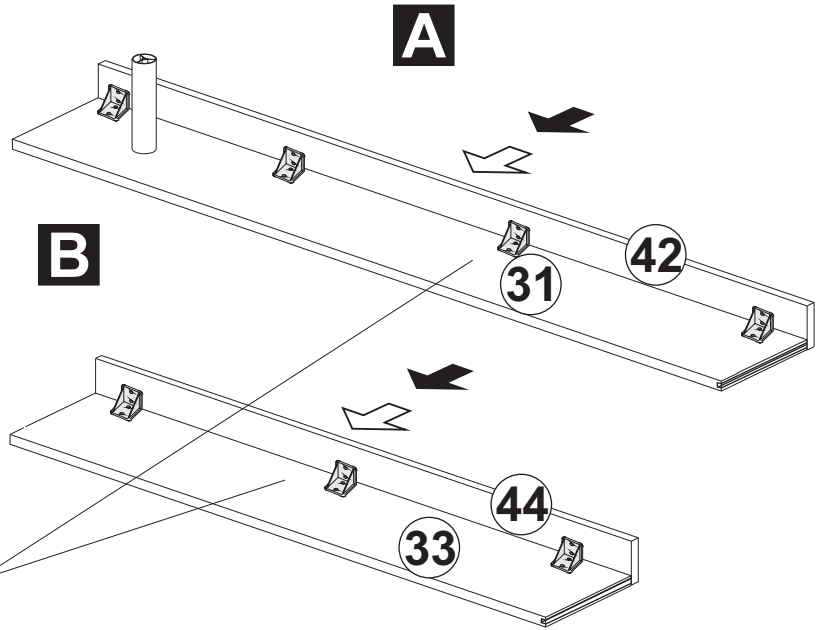
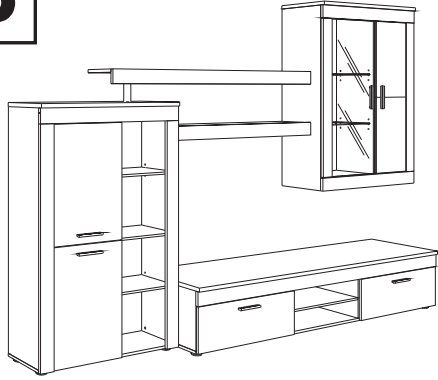

10B

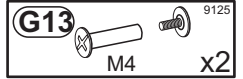
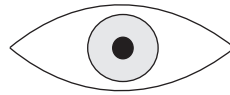

12B

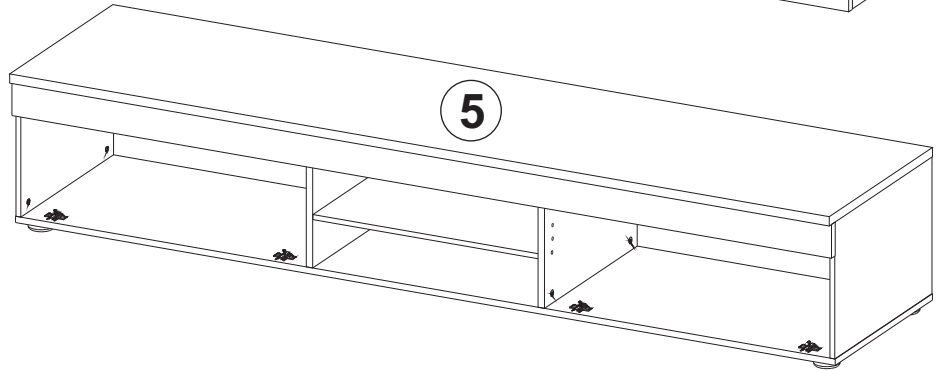
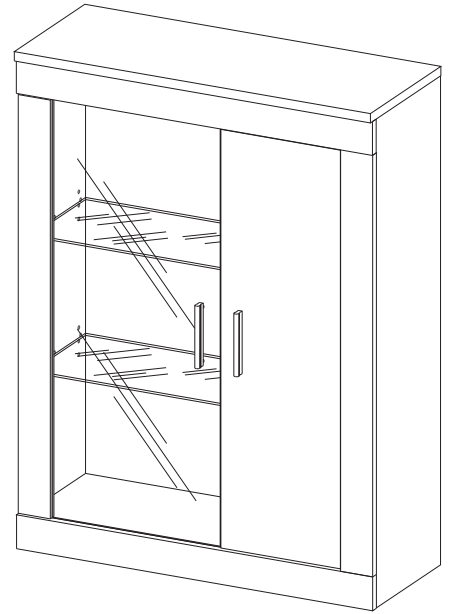
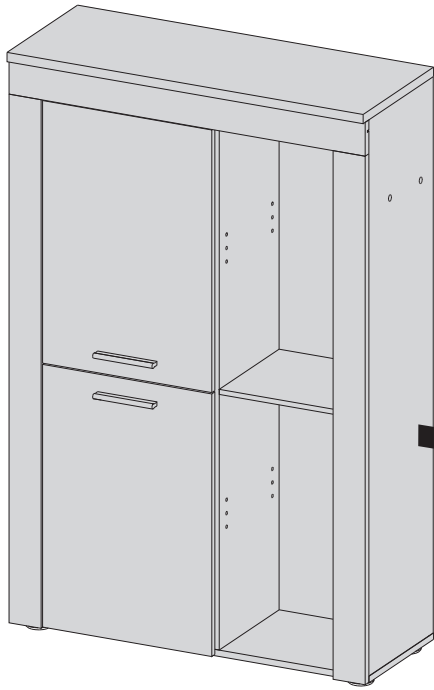

A

2x

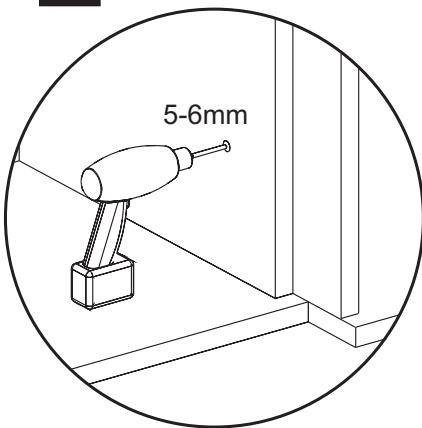

B

2x

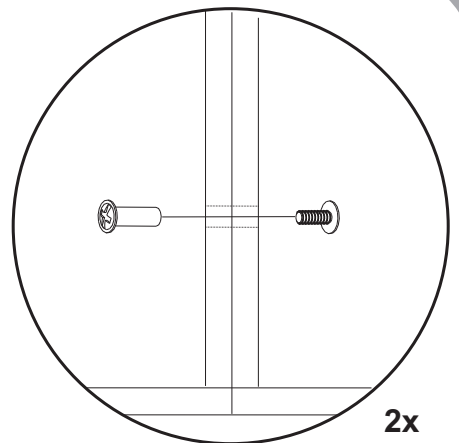
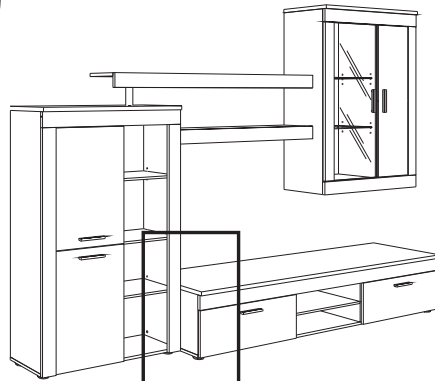
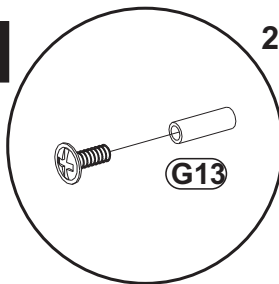

2x

C

11B

1 Schritt

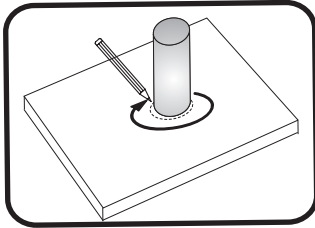

2 Schritt

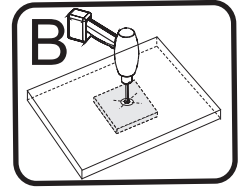
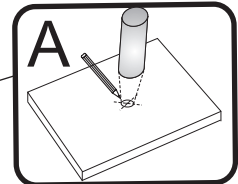
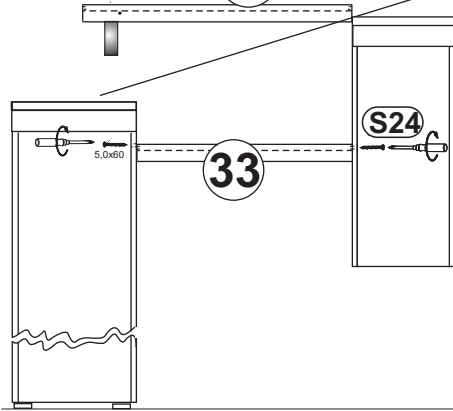

3 Schritt

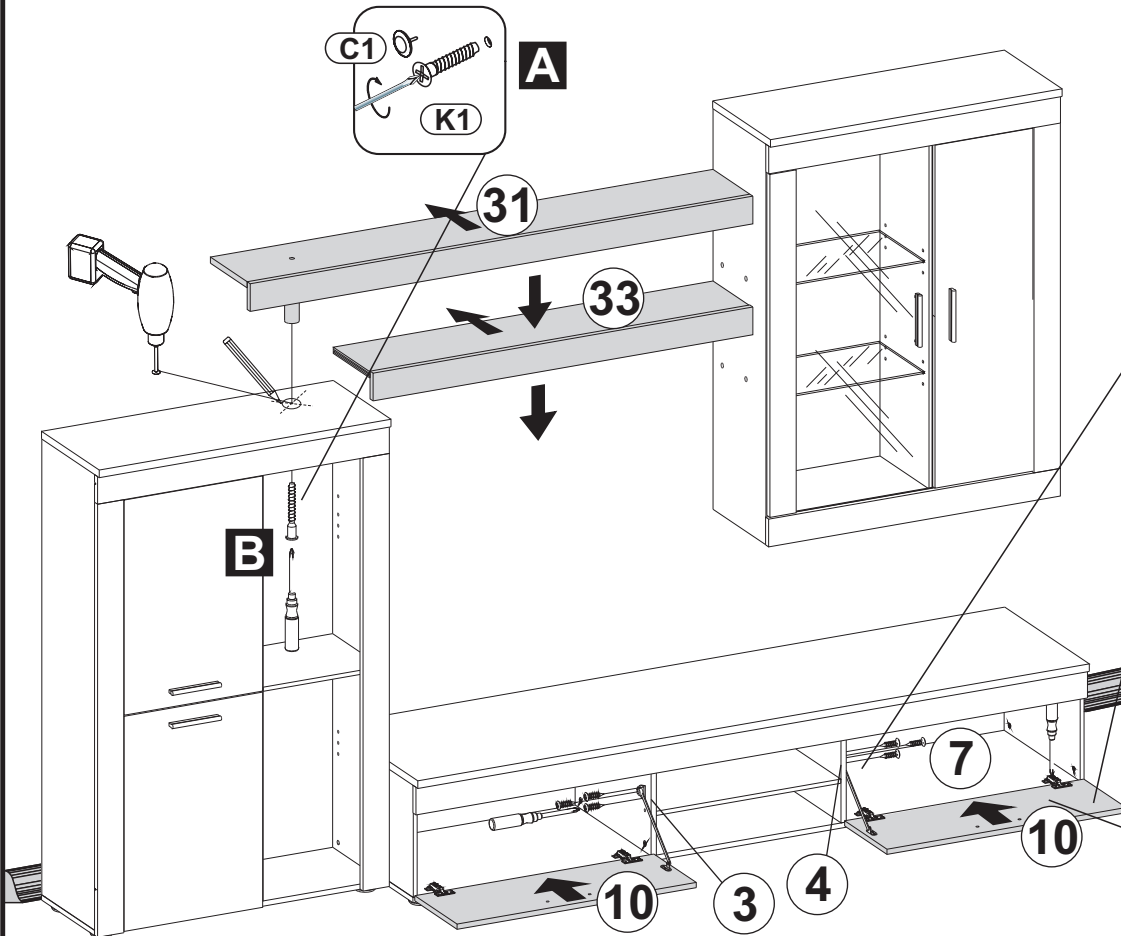
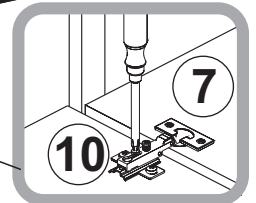
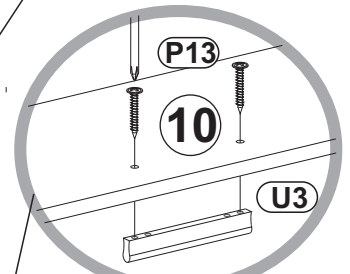
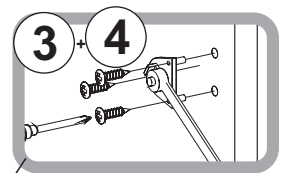
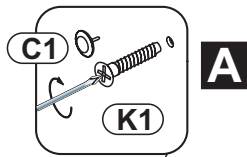
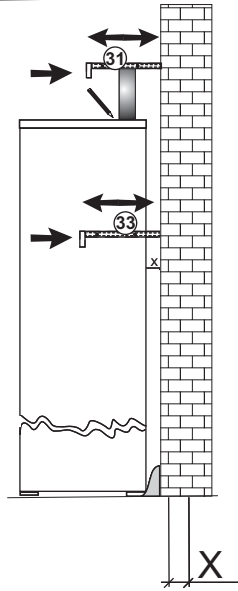
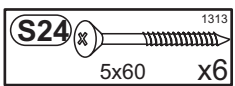
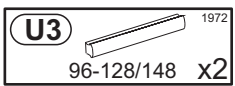
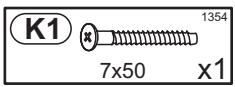
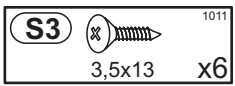
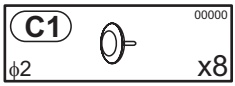
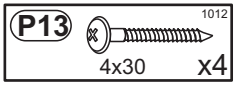
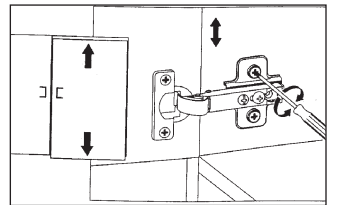
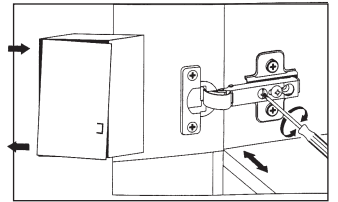
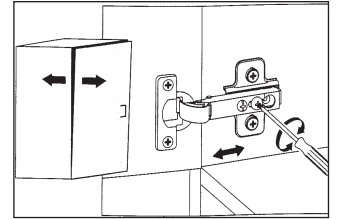
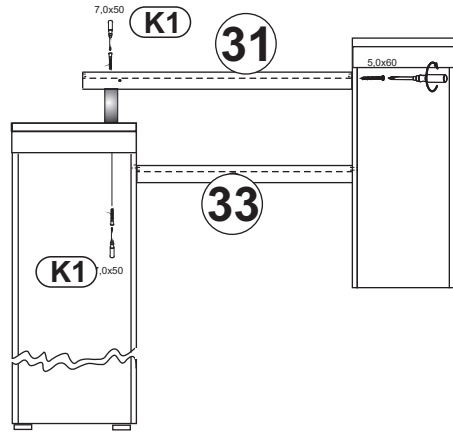

9C

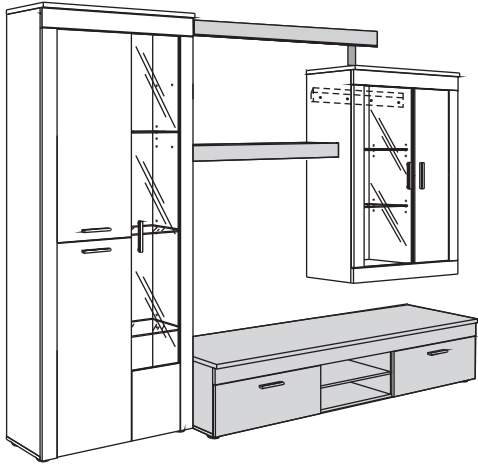

K14  0000
x2

S3  1011
3,5x13 x18

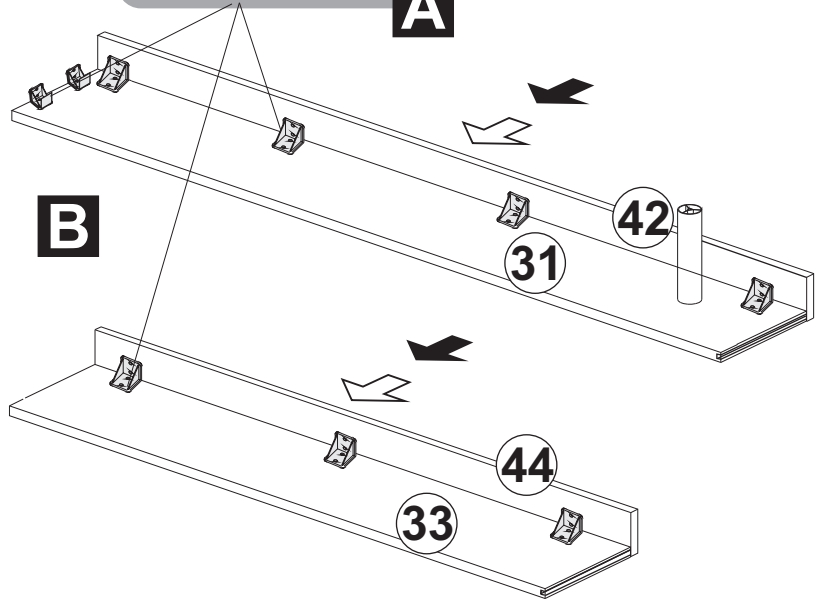
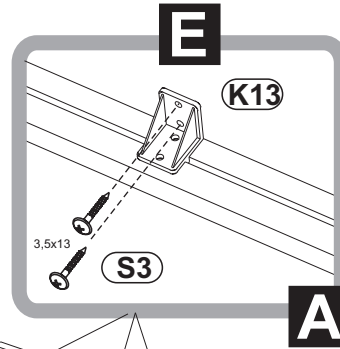

C

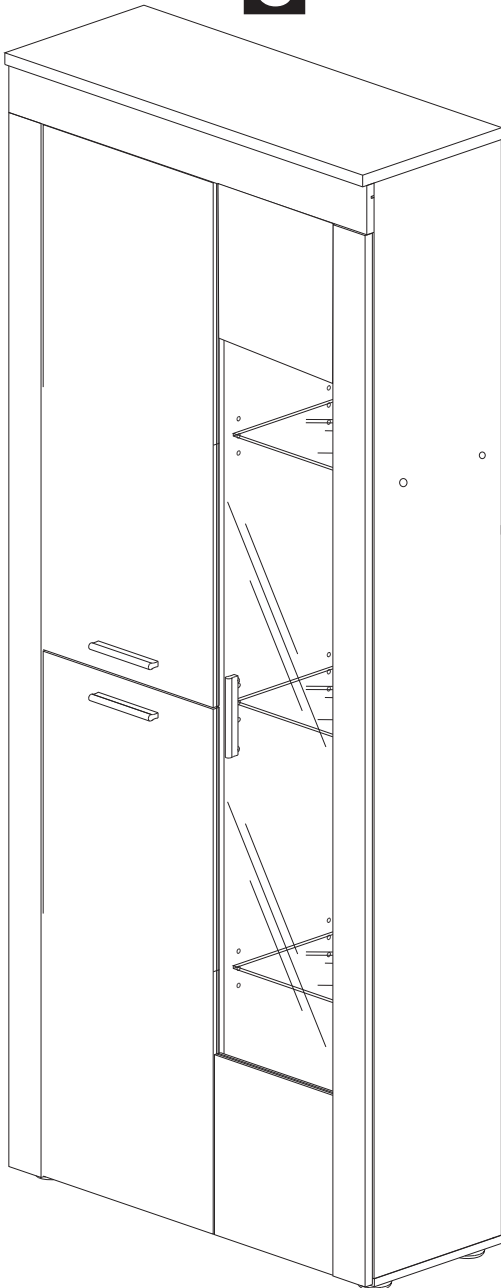

B

D

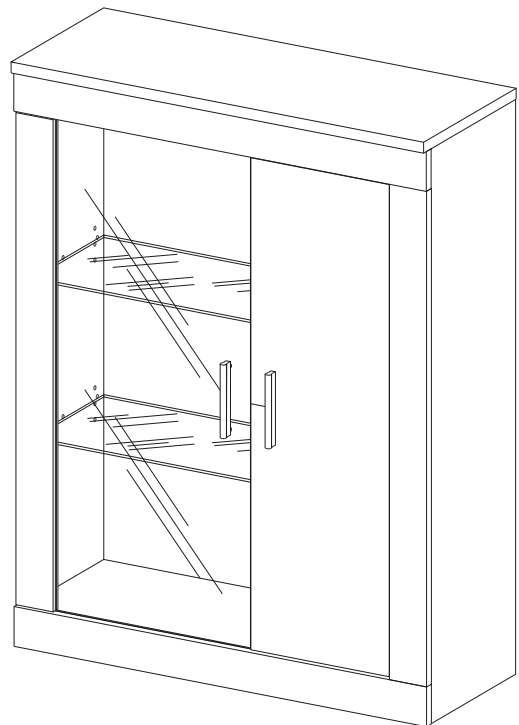

10C

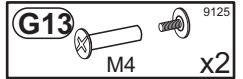
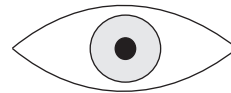

12C

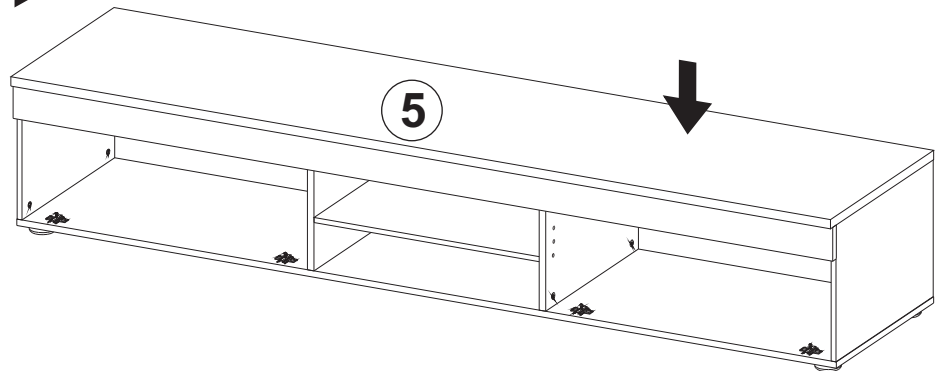
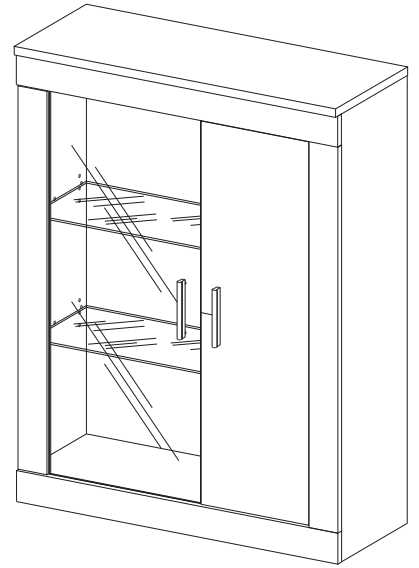
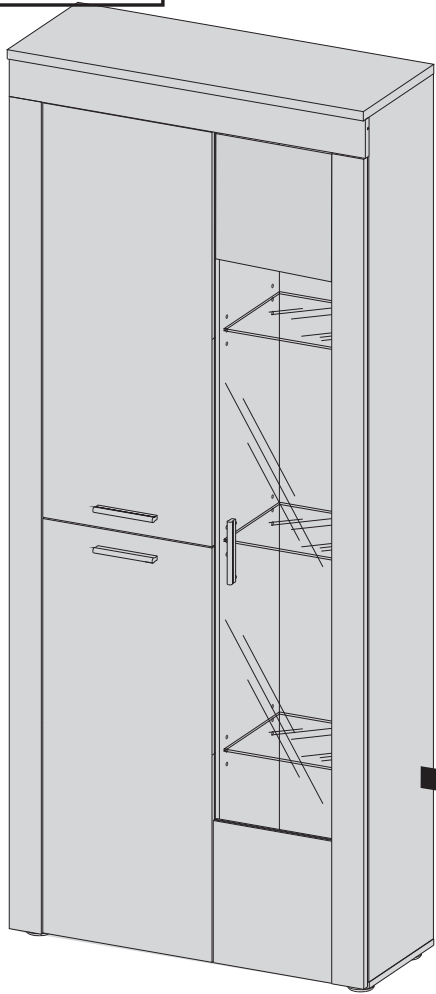

A

2x

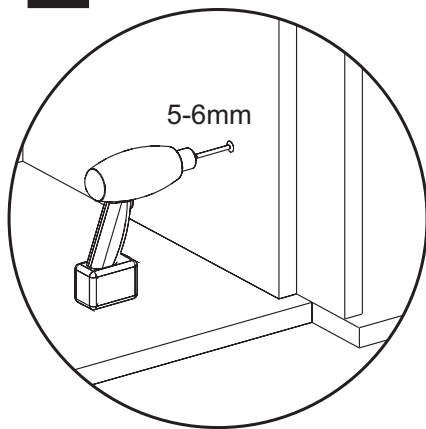

B

2x

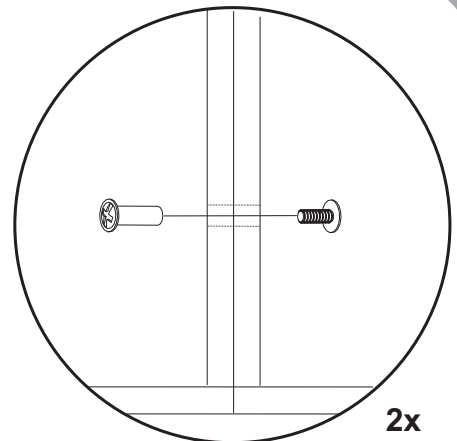
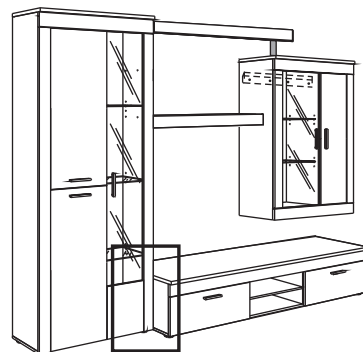
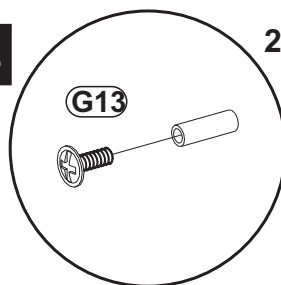



2x

C

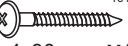
11C

P13  1012
4x30 x4

C1  00000
φ2 x8

S3  1011
3,5x13 x8

K1  1354
7x50 x1

U3  1972
96-128/148 x2

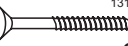
S24  1313
5x60 x6

1 Schritt

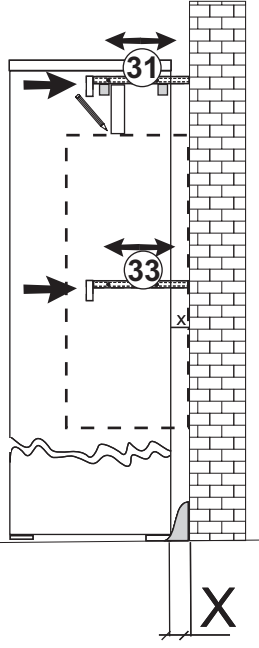

2 Schritt

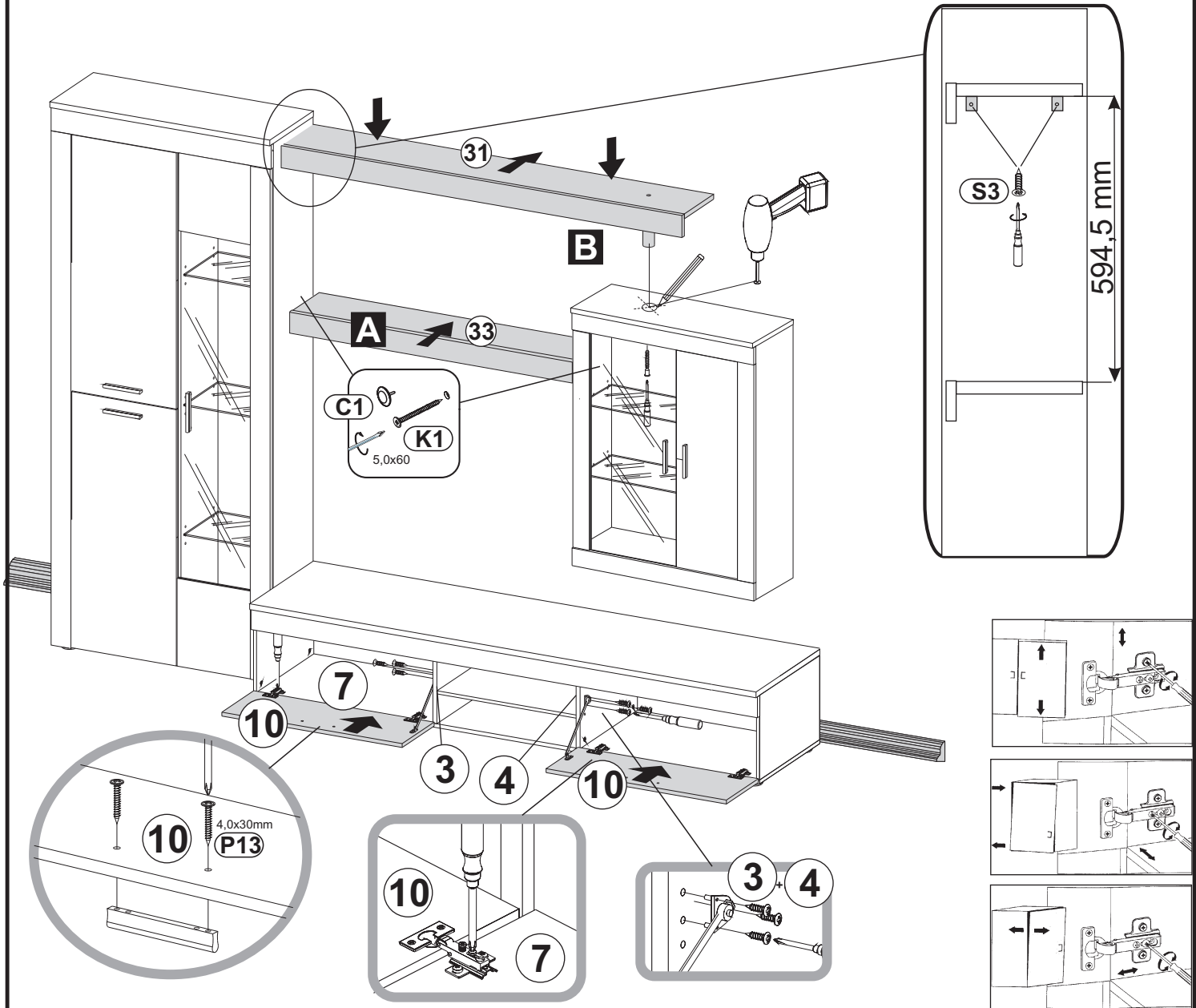
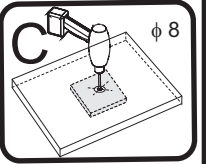
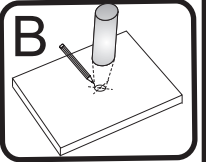
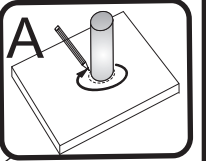
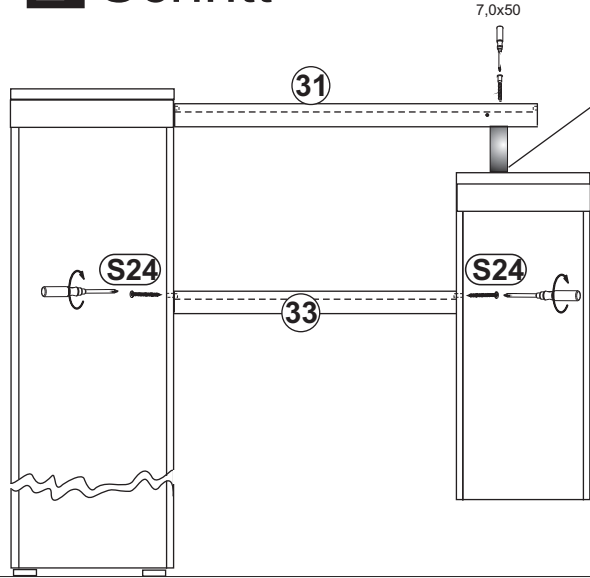

9D

S3  1011
3,5x13 x6

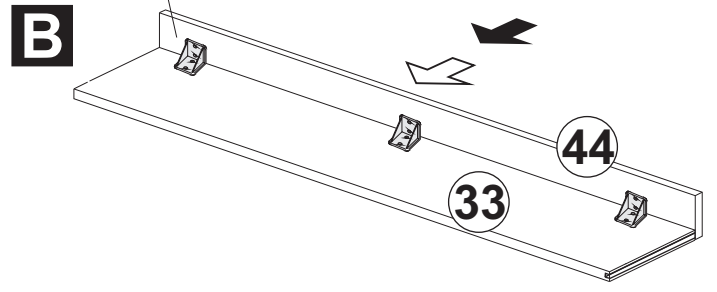
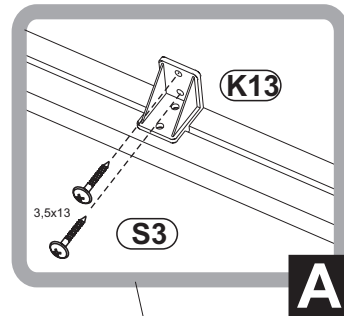
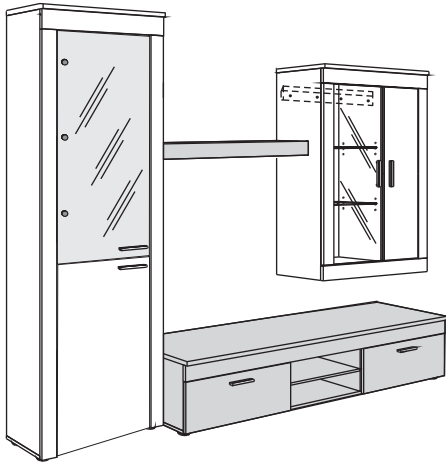

C

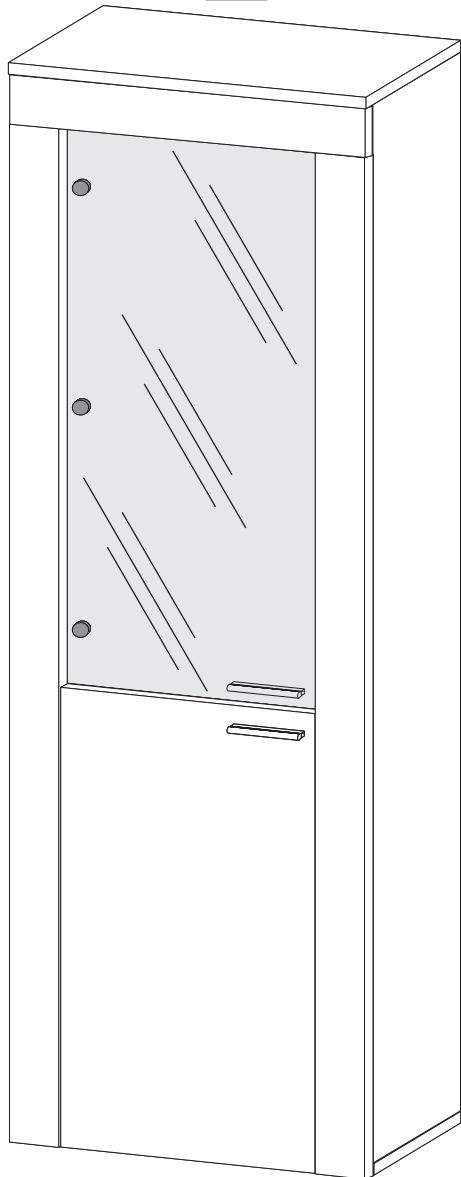

D

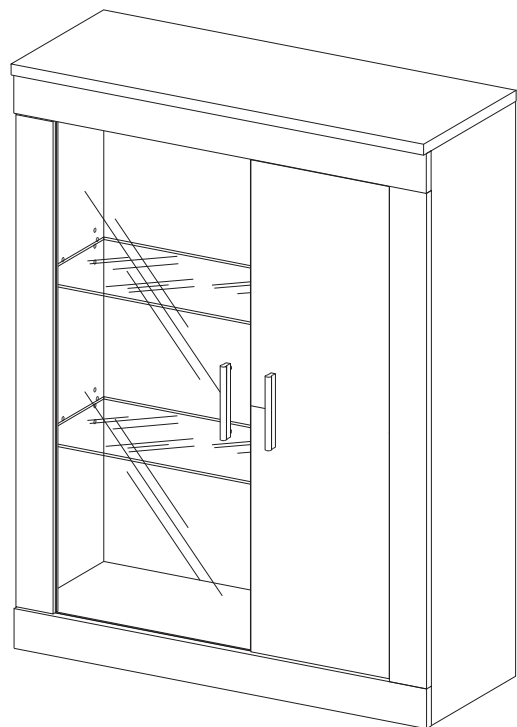

10D

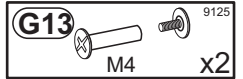
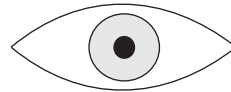

12D

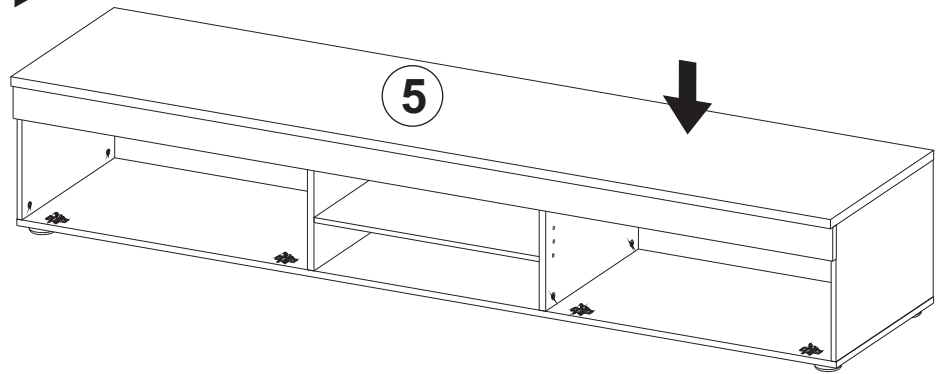
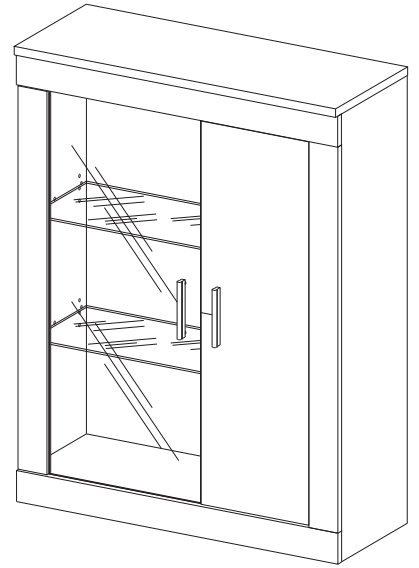
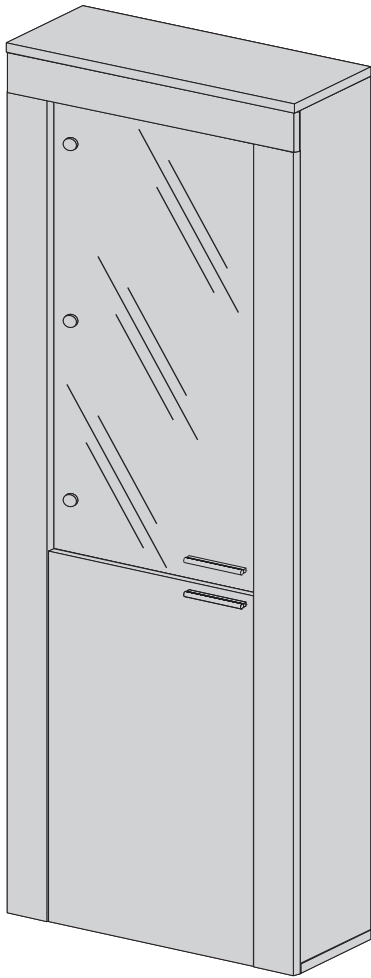

A

2x

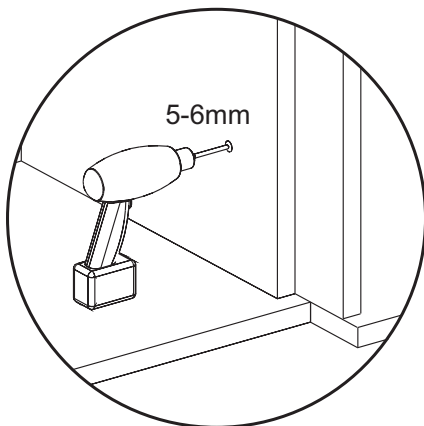

B

2x

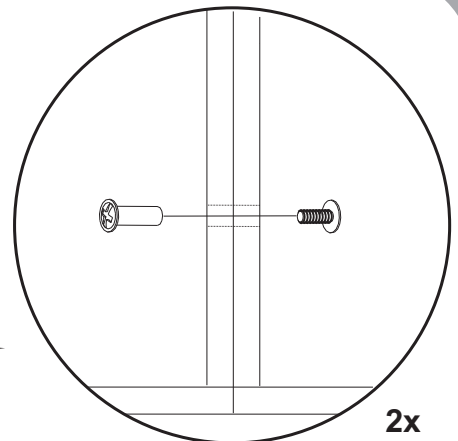
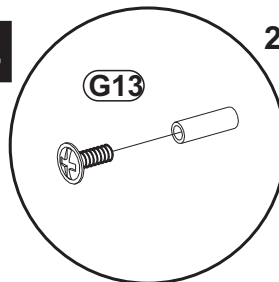

2x

C

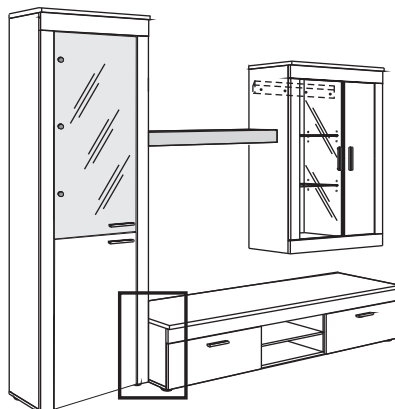

11D

1 Schritt

2 Schritt

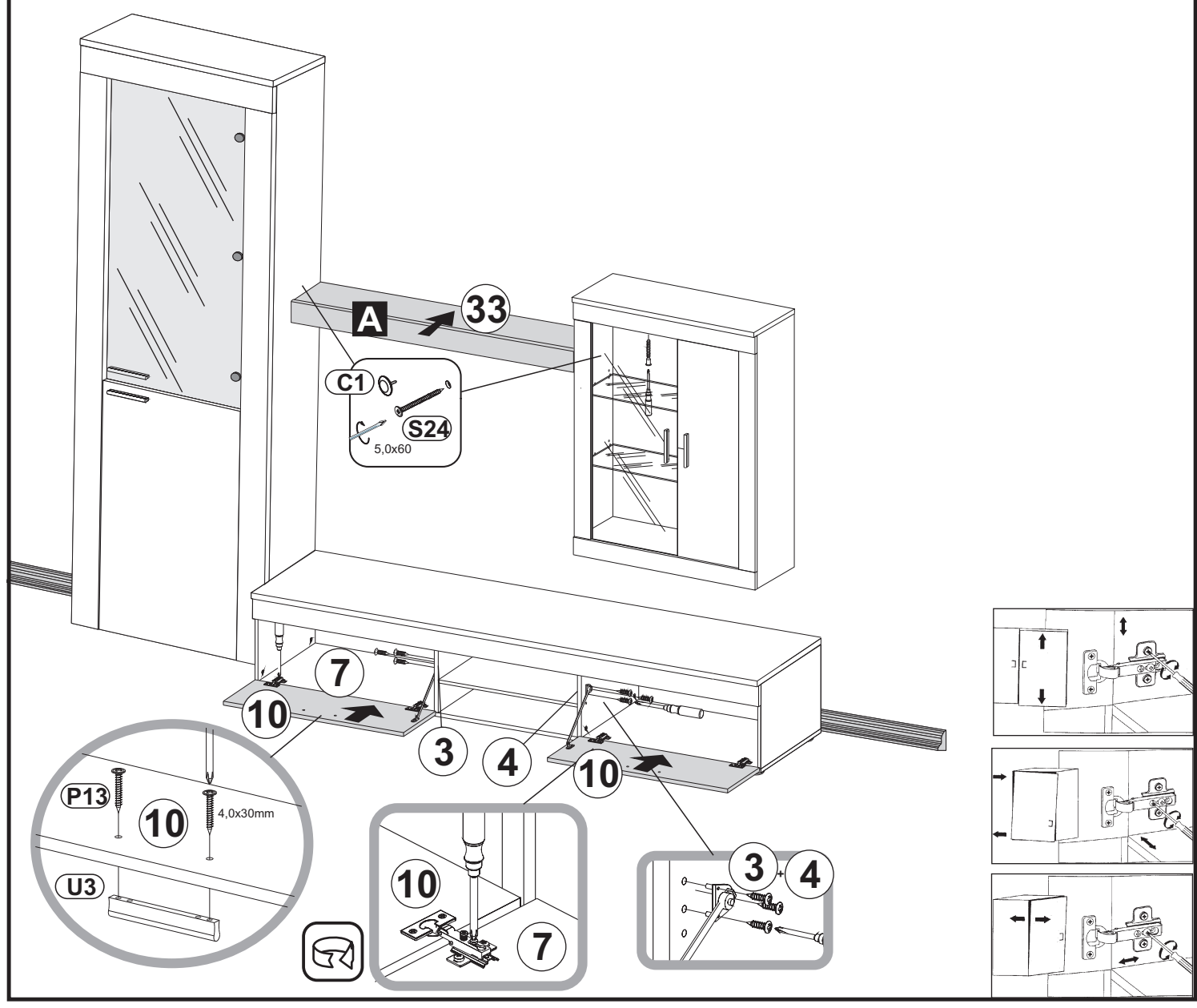
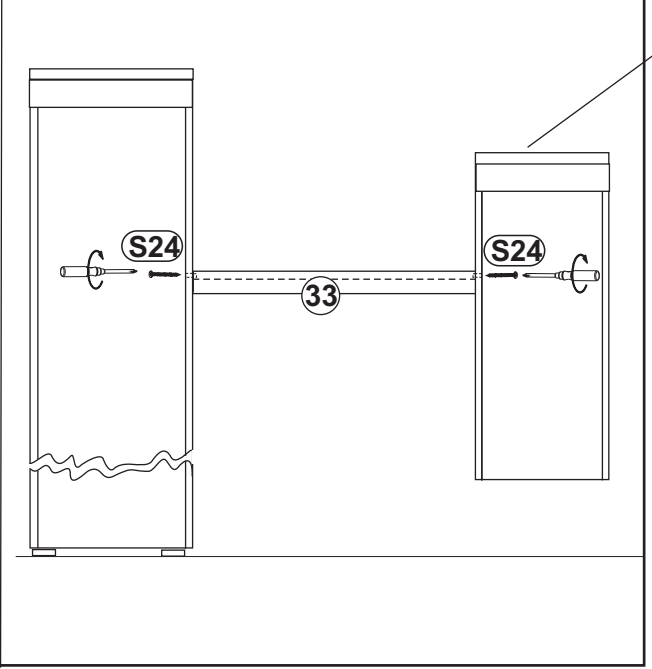
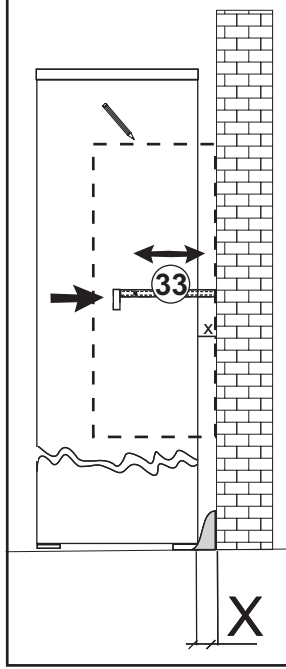
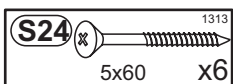
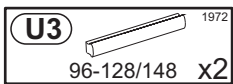
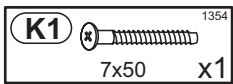
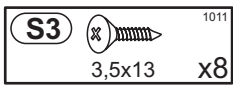
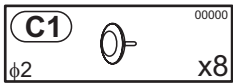
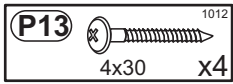

12A

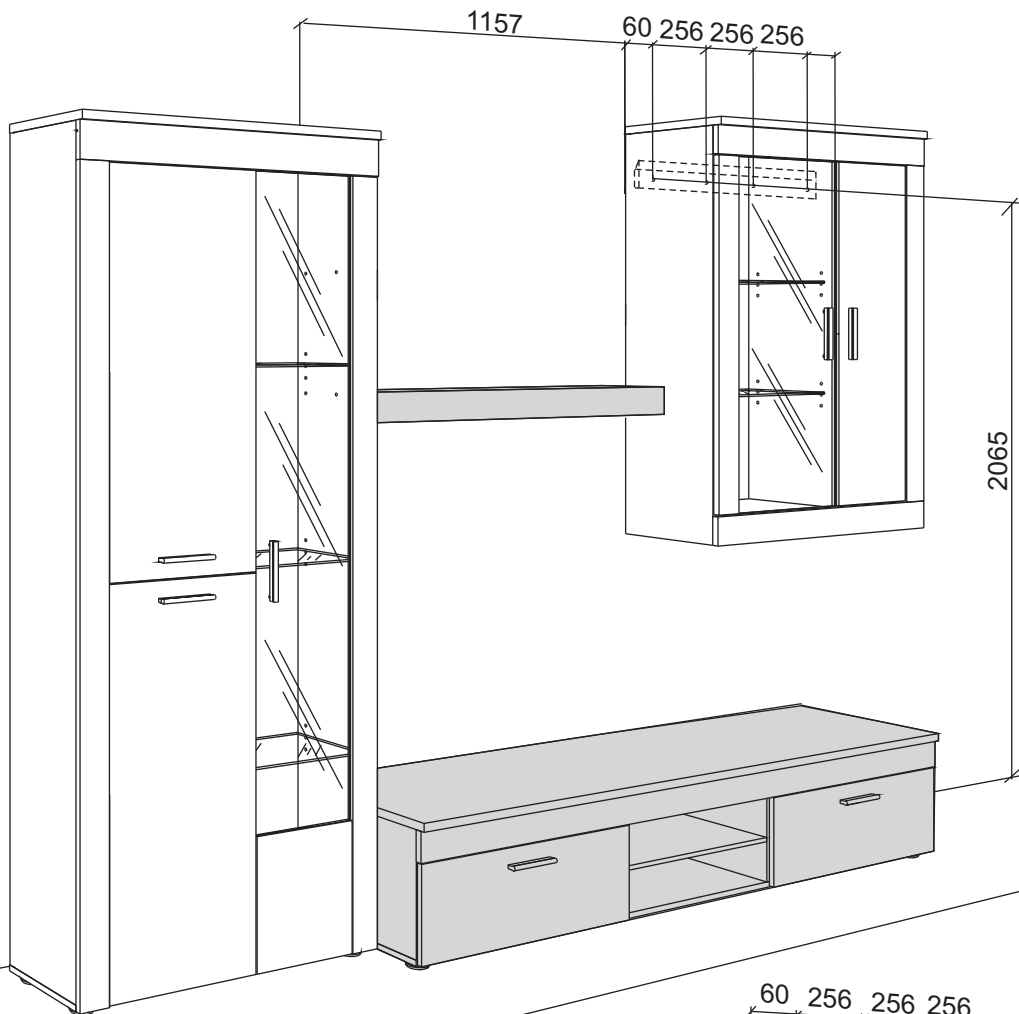

12B

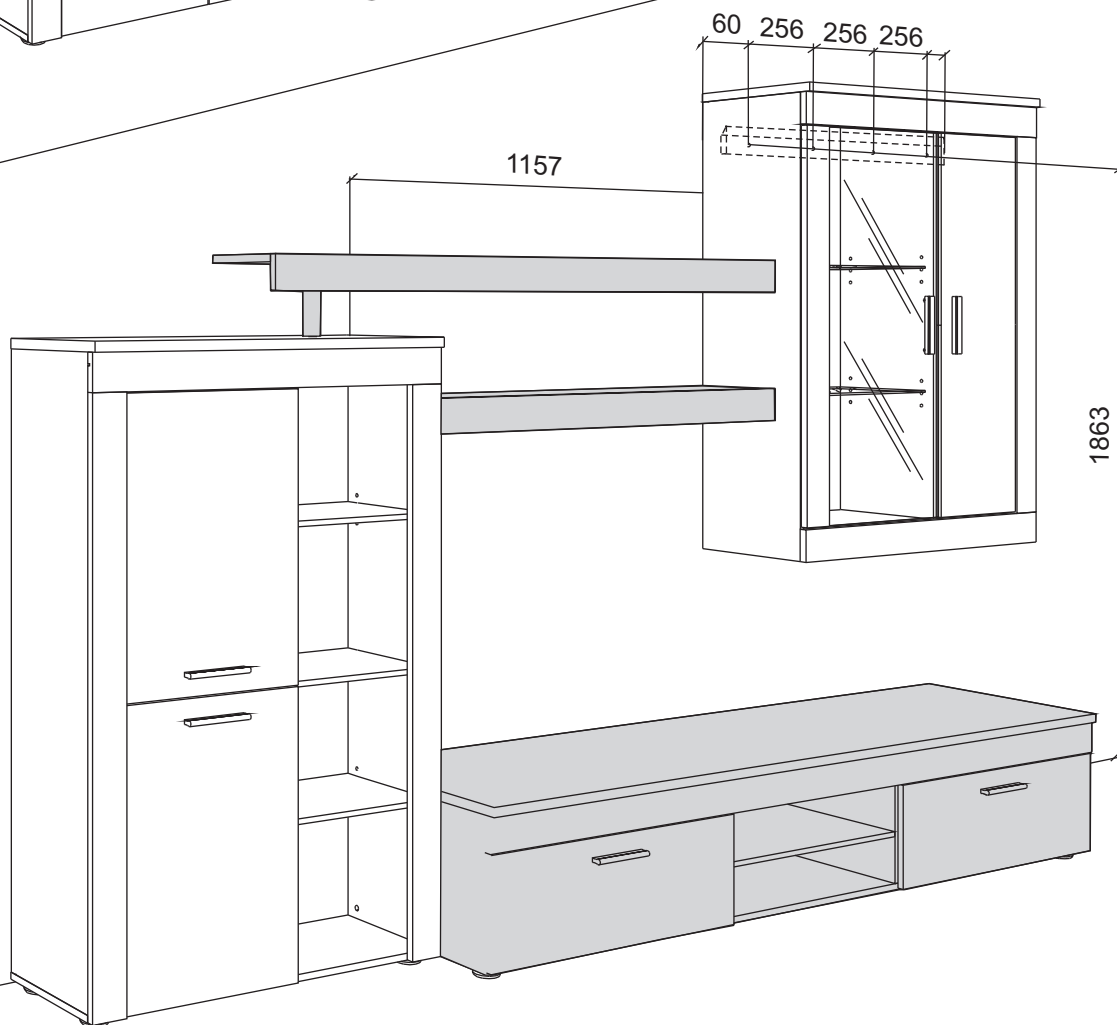

12C

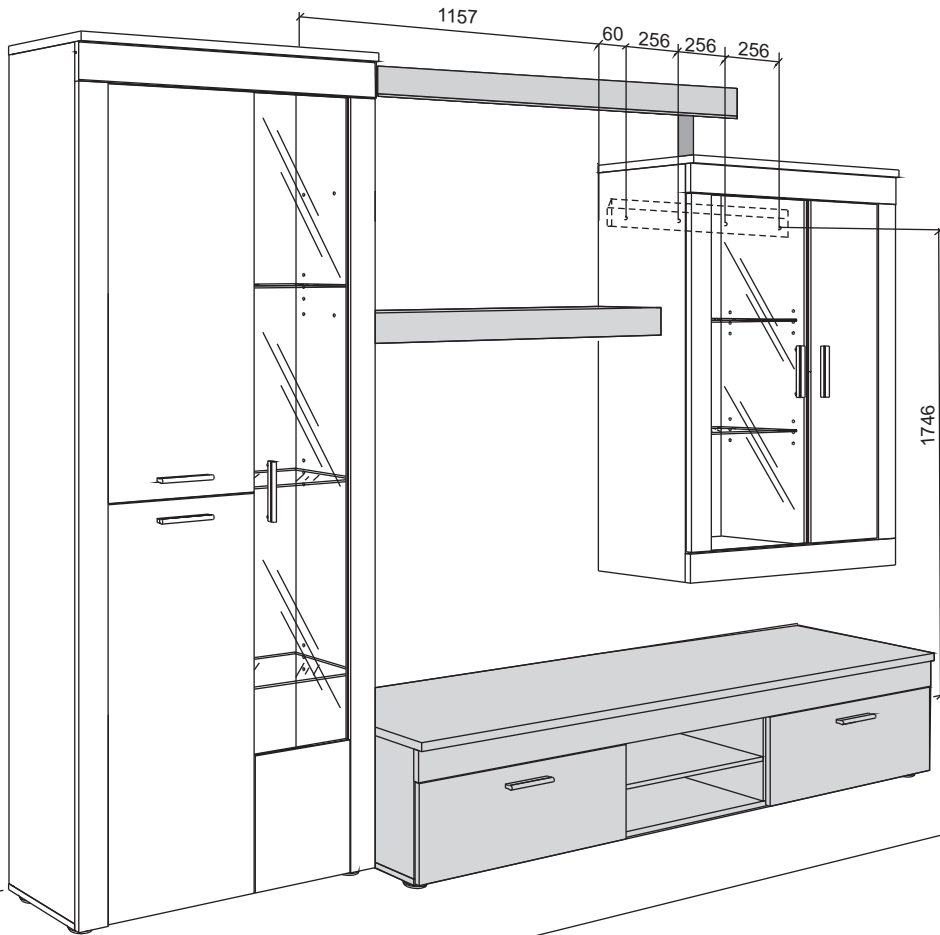

12D

